

**12000+**

schools  
participated

**15,500+**

original ideas explored  
and developed

**30,000+**

students  
engaged

# Macmillan Budding Scientists

**2026-27**

Powered By SPRINGER NATURE

in association with  
Indian Institute(s) of Technology

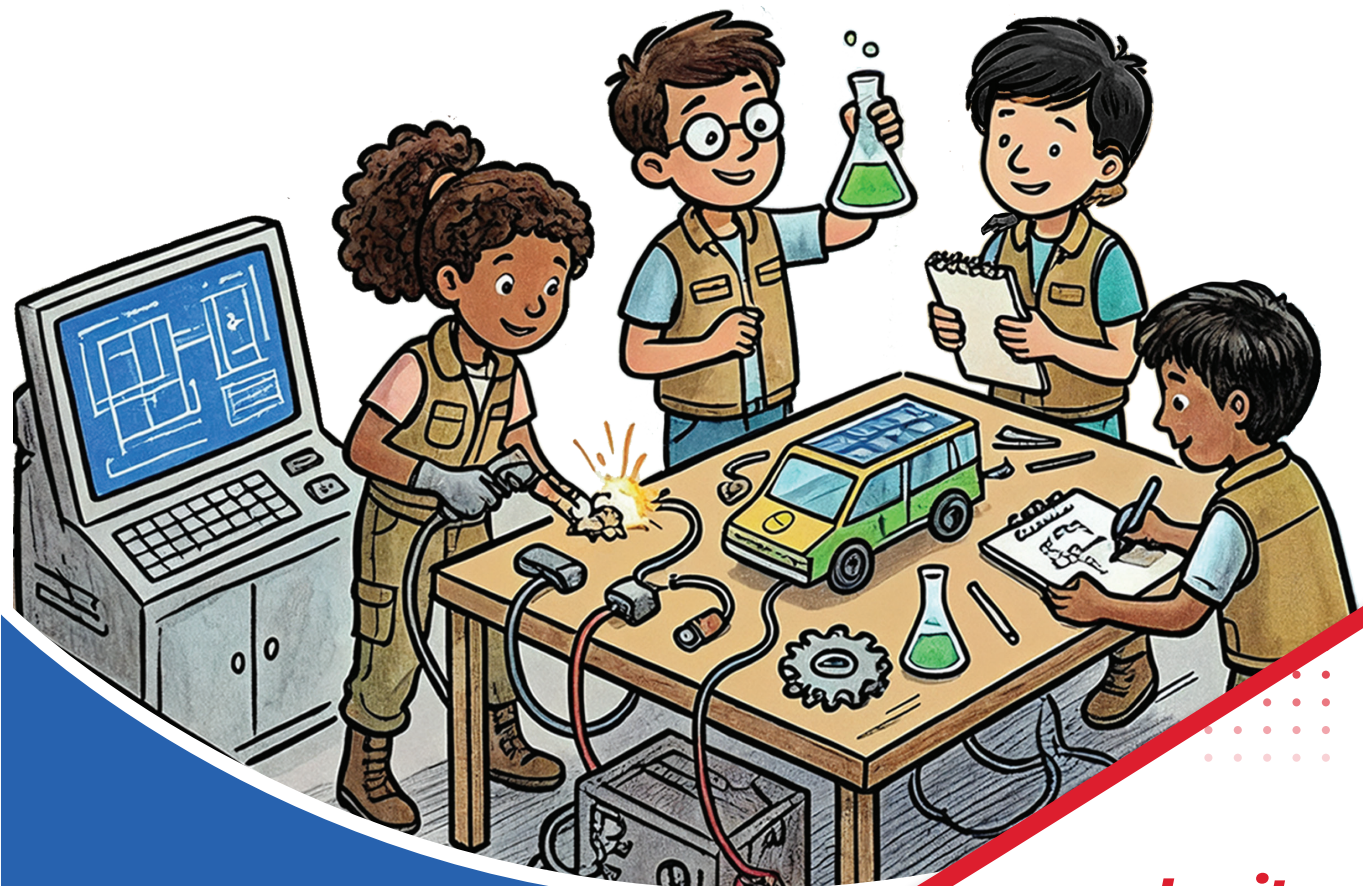

**Project Reference Book**

**Ignite  
Curiosity**

# Macmillan Budding Scientists 2026-27

Powered By **SPRINGER NATURE**

in association with  
**Indian Institute(s) of Technology**



# Contents

Foreword .....	iii
Message from the MD's desk .....	i
About <i>Macmillan Budding Scientist</i> .....	vi
Message from the Principal's Desk .....	viii
Macmillan Budding Scientist, powered by Springer Nature 2024-25 .....	1
Shortlisted Year-wise Finalist Projects - QR Codes .....	70



## Foreword



It was a pleasure for me to be approached by Macmillan Education India (MEI) in 2018 to explore the possibility of my involvement in their initiative “Macmillan Budding Scientist” (MBS). Right from the outset, it was clear to me that this was a somewhat unique beginning in the landscape of Indian school education system. At the time, I had already been professionally introduced to the school education system in India through: (i) several invited and “popular” guest lectures for school students both at IIT Delhi and/or their respective schools, (ii) an MHRD (now MoE) programme called IIT-Professor Assisted Learning (IIT-PAL) for class XI and XII school students that I was given the responsibility to initiate from IIT Delhi (along with a few of my colleagues), and (iii) an honour of serving as an “Eminent in Education” member in the management committee of a Kendriya Vidyalaya (KV) in Delhi. Through the latter two, it was my sheer privilege to closely interact with KV teachers, who inspired me to appreciate the key foundational roles school teachers play in our lives and the unparalleled efforts they put in towards executing their responsibilities, beyond any prior experience of mine.

In 2018, MEI took the bold step of advancing the concepts of co- and extra- curricular initiatives of the Government of India that aim at enhancing the school education experiences of students by integrating beyond-the-classroom exploratory avenues for teachers and students. Inspired by Neil Armstrong, I would go to the extent of stating *“That first Macmillan Budding Scientist in 2019 was one step for Macmillan Education India, but a giant leap for corporate involvement in the Indian education sector”*.

Having successfully completed three iterations since the first one in 2019, MBS initiative has fast established itself as a benchmark for recognising co- and extra- curricular academic efforts of student-teacher teams from schools across the country. While encouraging beyond-the-classroom engagements of teachers with their students in schools, MBS initiative encourages students who wish to push their educational explorations beyond their books. Additionally, an abstract achievement of the MBS initiative is that it recognises and celebrates those teachers who push their own limits in guiding students beyond classrooms. I feel privileged to have been asked to write this foreword for the first edition of this booklet showcasing projects of the MBS initiative. I hope that these projects will inspire students towards pushing the boundaries of their educational experiences beyond-their-classrooms but within-their-school-systems. More importantly, I hope this booklet will be seen as a first-of-its-kind effort in recognising the often-unsung champions in our society – the teachers in schools – who push their limits for every pupil entrusted to them.

**Prof Aditya Mittal, B. Tech., Ph. D.**  
Kusuma School of Biological Sciences,  
Indian Institute of Technology Delhi

## Foreword



The word “Science” refers to the state of knowing through questioning, answering, and solving problems. It starts off with basic questions like ‘Why is it happening?’ Is it possible to modify it? ‘The Macmillan Budding Scientist (MBS)’ programme aims to cultivate these urges in learners, guiding them to seek beyond their books and think about how science relates to the real world. By fostering curiosity and critical thinking, MBS empowers young students to engage with scientific concepts in a meaningful way.

IIT Delhi’s Academic Outreach & New Initiatives office has been supporting MBS for the past two years now, and we are proud as it complements our goal of bringing science to more schools and inspiring students to develop a scientific temperament. Science, in our opinion, is for everyone, especially for students who want to address real-life problems, pose thought-provoking queries, and come up with creative answers. This active and practical style of learning is what scientific research is based on.

A crucial aspect of this collaboration is the involvement of IIT Delhi’s research scholars, who not only contribute to MBS by evaluating the entries but also gain valuable insights from their experiences. Interacting with young curious students helps our scholars to experience science in a new light - one that is unfiltered by conventional academic boundaries. This interaction feeds their own inquisitiveness, which strengthens the essence of scientific curiosity. While interacting with the bright young minds, our researchers are refreshed on the principles of inquiry-based learning that helps formulate their own investigations.

I take great pride in the association with the ‘Macmillan Budding Scientist Programme’ and hope to sustain this partnership. By joining hands, we can create a world where every child is able to reason, investigate, and create, like a real scientist.

At IIT Delhi, we remain dedicated to helping young learners while also inducing a spirit of scientific inquiry. We salute ‘Macmillan Budding Scientist’ for nurturing the coming generation of problem-solver, researchers and innovators. Over the years, the programme has grown in scale and stature and now receives participation from over 1200 schools spread across India and the Middle East. Let us make deeper attempts to motivate, educate and research because the future of science starts here!

**Prof. Shilpi Sharma**

Associate Dean,  
Academics (Outreach & New Initiatives), and Professor,  
Department of Biochemical Engineering and Biotechnology,  
IIT Delhi

## Foreword



It has been my privilege to be associated with an initiative like ‘Macmillan Budding Scientist (MBS)’. Since its inception in 2019, the MBS initiative has completed six successful iterations and grown significantly, with many prestigious IITs joining hands to support this noble endeavour over the years.

Fostering a scientific temper among students and democratising science to make it more accessible are two objectives that are extremely close to my heart. MBS provides a unique platform for students, encouraging them to view science as an application-driven discipline while nurturing their boundless creativity. Through MBS, students not only apply their scientific knowledge to address real-world challenges—problems they encounter in their daily lives—but also gain the invaluable experience of life at an IIT. IIT Delhi, in particular, has been a beacon of inspiration, championing the cause of pursuing science and fueling curiosity.

The contributions of mentor teachers deserve special recognition. These dedicated educators invest themselves wholeheartedly to ensure their students excel, shaping young, inquisitive minds and inspiring them to explore science beyond the confines of textbooks.

Equally commendable are the principals and school leaders of the participating institutions. Creating an environment that encourages students to ask questions and think critically is no small feat. Their leadership fosters a culture of inquiry that is vital for nurturing the innovators of tomorrow.

I hope these projects inspire students to push the boundaries of their educational experiences, exploring learning opportunities that extend beyond the classroom while remaining rooted within their school systems. More importantly, I envision this booklet as a pioneering effort to honor the often-unsung champions of our society—school teachers—who consistently go above and beyond to empower every student entrusted to their care.

**Prof. Subodh Sharma**

Associate Professor  
and Pankaj Gupta Chair Professor in  
Privacy and Decentralisation,  
Department of Computer Science and Engineering, IIT Delhi



## Message From the MD's desk

Today STEM pervades every part of our lives and science's marvels can be seen and experienced everywhere we look in the world. STEM education links disciplines into a cohesive system and creates critical thinkers, increases science literacy, and prepares the next generation of innovators capable of transforming society through innovative solutions.

Being an integral part of India's education ecosystem, it is Macmillan's desire and duty to foster their interest, and ambition and give them a platform to showcase their creativity, which will spearhead tomorrow's technology.

At the Google Science Fair 2019, Tuan Dolmen from Turkey received the Scientific American Innovator Award for a digital agriculture module design that can capture tree vibrations. Further Aman KA and AU Nachiketh Kumar from India took home the National Geographic Explorer Award for a natural coagulant for rubber latex.

All of these children have done India proud, and we can't wait to see what they come up with in the future. You children should look up to young scientists like them as role models and strive to solve India's pressing problems, such as pollution, hunger and infant mortality.

I also encourage teachers to embrace STEM education because children are born with a natural curiosity for exploration and discovery.

We look forward to taking Macmillan Budding Scientist to schools across the country giving young learners an opportunity to showcase their ideas at a national level.

**Rajesh Pasari**

Managing Director  
Macmillan Education India

## About Macmillan Budding Scientist



I remember the town hall hosted by the entire Springer Nature senior management team, on a cool November evening in 2016, in India. The Springer Nature group launched an innovative initiative to encourage and develop scientific talent in schools across India - Macmillan Budding Scientist, powered by Springer Nature. The thought behind it was to develop curiosity and scientific temper in young learners and promote research and innovation for sustainable development. The announcement came after an education conclave was organized by Springer Nature to discuss strategies and evolve solutions to challenges in science education in the years ahead. This initiative was to be integrated with the efforts of IIT Delhi towards school outreach and taken to thousands of schools in India, by Macmillan Education India. I would like to acknowledge the support of Ms. Subhra Priyadarshani, Chief Editor, Nature India who was instrumental in the conceptualization of the Budding Scientist initiative, enabled the partnership with IIT, and promised workshops on Science Communication to students.

At the launch event, a student of Amity International School Gurgaon Vaishali Tikko, was honoured by Springer Nature for the novel instrument she developed to help her fellow students facing learning difficulties. From 2016 to 2022 Macmillan Budding Scientist has grown in stature and today the engagement with IIT Delhi has extended to IIT Mumbai, Bhubaneswar and Chennai. This will allow more students across the country to experience Science.

Macmillan Education is looking to expand this programme in the coming years and deepen its impact.

**Vandana R Juneja**

Director Marketing  
Macmillan Education India



Vaishali Tikko, of Class XII was awarded as the budding scientist for her project titled- Novel instrument to detect learning disabilities in children by Macmillan Education. School Principal, Mrs Arti Chopra was also bestowed for fostering scientific talent.

## From the Principal's Desk



Navrachana is committed to providing its students holistic education and provide a learning environment that will build, nurture and develop the trinity of faculties in every student- mental, physical and emotional.

At Navrachana, we believe that curiosity is the key to fostering the spirit of excellence. All our efforts in class thus, are geared to induce curiosity in students, to make them ask two magic questions: why, and why not? And it is with this questioning of the world around us that our students develop a scientific temperament. When they ask “Why?”, they delve into the wonders of science and when they ask “Why not?”, they embark on a quest to use science to better the world.

This scientific streak of curiosity that emerges in every student is eventually how ideas take root in classrooms. And with the guiding hands of our teachers, these ideas finally transform into solutions that take flight. We place a strong emphasis on holistic development, so our goal is to provide students with ample of opportunities to explore their interests and passions.

**Ms. Suprabha Menon**

Principal,

Navrachana Higher Secondary School,

Sama, Vadodara (Gujarat)

## From the Principal's Desk



We live in an age where science and technology are transforming every aspect of our lives. From the way we communicate and travel to how we access information and solve global challenges, science is at the heart of it all. As an educational institution, we have the responsibility and privilege of preparing our students for a world that is driven by scientific advancements.

The students at the Broadway International School are given opportunities to explore, question and reason out even at the Pre-Primary level. Their curiosity is enhanced by taking them to various inter-school competitions. The idea is to develop a balance of scientific temper and linguistic abilities for them to be able to express their concerns and to find answers to all the unanswered questions. Organizing field trips to science museums, laboratories, or inviting professionals and scientists as guest speakers, exposure to real-world applications and interactions with experts have been quite inspiring for students. Our commitment to fostering scientific skills extends beyond the classroom creating an ecosystem where students not only learn theories but also actively engage in scientific exploration. By integrating all the above we strive to inspire a lifelong love for science and empower the next generation of innovators and problem solvers.

**Ms. Rachana Desai,**  
Principal,  
Broadway International School, Surat.

## From the Principal's Desk



I extend my heartfelt gratitude to Macmillan Education team for their initiative which has left an indelible mark on the students of Gaikwad Global School, inspiring them to pursue excellence in academics and beyond. Activities like these by Macmillan Education are appreciable and are integral to nurturing future generations from across the country who are waiting for opportunities like these. Participation in events like the Macmillan Budding Scientist is not just an exercise in showcasing talent; it plays a vital role in achieving the dream of making 'Bharat - a Super Power' by inculcating a love of science, igniting curiosity and innovation amongst the youngsters of India.

We at Gaikwad Global School are determined towards developing scientific temper among our students by providing them multidimensional exposure through our teachers, resources and the events that we organize. Students are motivated to think beyond textbooks, explore new ideas, and develop practical solutions to real-world problems. We have always been at the forefront of promoting science and technology in our campus by organizing in-house annual science exhibition, field trips, industrial and campus visits, public rallies, awareness campaigns and so on.

The GGS Science Club (Affiliated to VIPNET, Ministry of Science & Technology, Govt. Of India) provides exposure to our students to undergo a wide spectrum of activities that paves the way to build a strong connect with scientific thinking and research.

We are one of the proud schools in our region who have been certified as "Eat right school" by FSSAI, Ministry of Health and Family welfare, Govt. Of India, by conducting eat right activities at our school due to which our students not only learnt to eat right and stay healthy but also acquired the skills of how to build a healthy society.

Gaikwad Global School, Chhatrapati Sambhajnagar takes immense pride in its young scientists and looks forward to their continued success in upcoming endeavours.

**Dr. Sulekha Dhage,**  
Principal,  
Gaikwad Global School,  
Chhatrapati Sambhajnagar

## From the Principal's Desk



As the Principal of this esteemed institution, I am proud to share how we are fostering scientific acumen among our students. Our vision is to nurture inquisitive minds capable of exploring the world through the lens of science. To achieve this, we have integrated a robust science curriculum that encourages critical thinking, experimentation, and problem-solving from an early stage.

We emphasize hands-on learning experiences, with students actively engaging in laboratory experiments, field trips, and science fairs. These opportunities not only allow them to apply theoretical knowledge but also spark curiosity and creativity. Additionally, we host regular workshops and

invite experts in various scientific fields to inspire and broaden students' understanding of real-world applications.

Technology plays a key role in our approach, with interactive tools and digital resources that make learning more dynamic and accessible. We also promote interdisciplinary learning, where science is connected to other subjects like mathematics, art, and environmental studies, providing a holistic view of the world.

Our goal is to cultivate a generation of innovative thinkers who can apply scientific principles to address challenges and contribute meaningfully to society. By fostering a passion for discovery, we are preparing our students to become future leaders in science and technology.

**Ajay Bahadur Singh,**

Principal,

Mithi Gobindram Public School, Bhopal

## From the Principal's Desk



I, Fareha Gaus Sayed, Principal of New Grace English School, firmly believe that nurturing scientific curiosity is pivotal to shaping the future of our students in an ever-evolving world.

In our school, fostering scientific acumen goes beyond the classroom. We strive to create a culture that celebrates curiosity, critical thinking, and creativity. Our teachers receive ongoing professional development to ensure they are equipped to inspire and guide students effectively. Through initiatives like science clubs, robotics teams, and environmental activities, we empower students to explore, innovate, and solve real-world problems.

The success of our students in competitions like the **\*\*Macmillan Budding Scientist\*\*** exemplifies this commitment. Their innovative project, the Flexible Highway Barrier, is a reflection of their ability to think critically and propose solutions to pressing societal issues. This achievement underscores our mission to prepare students for a future shaped by science and technology.

As educators, we remain committed to inspiring the next generation of thinkers and innovators, ensuring they are equipped to navigate and contribute to a rapidly changing world. Together, let us continue fostering a spirit of scientific excellence and curiosity in our students.

**Fareha Gaus Sayed,**  
Principal,  
New Grace English School, Pune

## From the Principal's Desk



Mahatma Gandhi rightly said “The best way to find yourself is to lose yourself in the service of others.” Firmly believing in our core values of Courage, Compassion, Equality and Integrity we at Sanskar Vidya Sagar aim to nurture our students so that they are well equipped to face the competitive society with value-based knowledge and skills that have contributed towards the growth and vision in building global citizens and a conscientious humanity.

Keeping in mind that to teach is to touch a life forever, we believe in holistic education that encompasses academics, co-curricular activities, sports and life-skills learning. As we venture ahead and spread our wings in this spectacular valley of value-based education and a robust curriculum that opens the door to global platforms for our peace loving and problem-solving students. Activities and events related to value education, environment, health education, games and sports, visual and performing arts, culture and heritage, personality development are effectively woven into the main fabric of school curriculum.

I take this opportunity to thank Macmillan Team for organising such a wonderful platform for students to experience dream making true.

**Mrs. Shweta Deshpande,**  
Principal,  
Sanskar Vidya Sagar, Nandanvan, Nagpur.

## From the Principal's Desk



In today's fast-paced, technology-driven world, scientific literacy is a necessity. Schools play a pivotal role in cultivating scientific acumen, which encompasses curiosity, critical thinking, problem-solving and a deep understanding of scientific principles. At St. Joseph's High School we have left no stone unturned building this foundation from an early age which equips students to navigate and contribute to a rapidly evolving global landscape.

The motto of our school 'Excellence in education and all round development' has paved the way to equip students with the skills and mindset to tackle the challenges of the future. Hands-on activities, such as experiments, model-building, and fieldwork are conducted. Group projects not only build teamwork but also hone communication skills, essential for articulating scientific ideas effectively. Teachers incorporate case studies, debates, and problem-solving exercises into the curriculum to challenge students to think. Inviting guest speakers from scientific fields further ignite students' passion for science.

As educators, facilitators it is our collective responsibility to ensure that every student has the opportunity to unlock the wonders of science and contribute meaningfully to society. Thank you for such a platform and best wishes to every participant of the 'MacMillan Budding scientist 2024'.

**Mrs. Leena Verma,**  
Principal,  
St Josephs's High School CBSE, Panvel

## From the Principal's Desk



At The Jain International School, Nagpur, we believe in empowering young minds with the tools of scientific inquiry, critical thinking, and innovation. Our holistic approach integrates modern teaching methodologies, advanced infrastructure, and experiential learning, ensuring students develop a robust scientific temperament. We have well equipped laboratories for Physics, Chemistry, and Biology, where students actively engage in experiments that bridge theoretical knowledge with practical application. Our curriculum goes beyond textbooks, incorporating interdisciplinary learning and problem-solving activities.

Our Science Club serves as an enriching platform where students can explore their scientific interests beyond the classroom. This club allows students to engage in exciting experiments, discussions, and collaborative projects that ignite their curiosity and encourage critical thinking.

In line with the government's vision to promote innovation and entrepreneurship, we have established the Atal Tinkering Lab (ATL) at our school. The ATL provides students with a dynamic, hands-on environment where they can experiment with technology, electronics, and robotics. By designing prototypes, working on real-world issues, and tinkering with new ideas, students gain practical exposure to the STEM fields, learning how to turn theoretical knowledge into tangible innovations.

We nurture a culture of inquiry through project-based learning, where students identify societal problems and propose innovative solutions. Participation in national and international science fairs, olympiads, and competitions further sharpens their analytical skills and confidence. Our dedicated faculty members mentor students, guiding them to explore, question, and innovate.

At The Jain International School, Nagpur, our goal is to nurture scientifically literate individuals who are prepared to lead with curiosity, creativity, and a sense of purpose in a rapidly evolving world. By fostering scientific acumen, we aim to shape thinkers and innovators of tomorrow.

**Ms. Anmol Badjatia,**  
Principal,  
The Jain International School, Nagpur

## From the Principal's Desk



With unwavering faith in the transformative powers of Science, Chettinad Vidyashram places profound emphasis on cultivating a spirit of inquiry and a scientific temper in its students. As we head towards a future powered by discovery and progress, the school keenly promotes scientific acumen in order to nurture critical thinking, innovation and a rational approach in youngsters.

The school has fully functional and state-of-the-art science laboratories where students gain hands-on knowledge and expertise. To enhance industry knowledge, students are engaged in immersive hands-on field explorations to hospitals, museums and research institutes at frequent intervals. Chettinad Vidyashram's biennial Science Expo is a haven for

science enthusiasts, as this mega STEM festival showcases live projects, working models and innovative and strategically thought-of solutions for problems that plague the world. This science carnival witnesses innovative initiatives not just in science but in other realms like humanities, commerce etc. Considering that an analytical approach is intrinsic for any valid development, the school encourages all disciplines to showcase their progressive ventures on these two days of the Science Fest.

The school's curriculum has been conceived from a scientific perspective as there is a radical shift from rote learning to an approach propelled by science and rational thinking. Interdisciplinary projects and activities for students of all classes, seamlessly blend science with the other domains. To complement, textbook learning, students are exposed to experiments related to daily life, which is one of the easiest and most effective ways of fuelling critical reasoning. Science based games and challenges are an integral part of our classroom transactions.

The school encourages students to participate in science competitions and events where they get a chance not just to prove their scientific calibre but also to broaden their horizons. Chettinad Vidyashram encourages students to partake in Olympiads and other competitive exams that can help hone their intellectual rigour. By providing a multitude of opportunities for students to explore in their pursuit of scientific enlightenment, the school's alumni roster proudly boasts a distinguished line up of innovators, pioneering scientists, and enlightened global citizens.

**Dr. S Amudha Lakshmi,**  
Principal,  
Chettinad Vidyashram, Chennai

## From the Principal's Desk



The future of education is on the brink of transformation. Children now prefer to experiment, and solve real-world problems rather than just learning from textbooks. At Gitanjali Devshala, we support this transformative approach by offering a classroom setting that encourages creative thinking and equips students with the tools they need to tackle problems in the real world.

### **Igniting Scientific Curiosity Through Hands-On Exploration**

We spark curiosity through hands-on learning, encouraging students to ask questions and find answers through experimentation. Activities like building simple machines and designing eco-friendly solutions inspire excitement for science from an early age.

### **Teaching Tomorrow's Innovators Today**

Our teaching methods include inquiry-based learning, STEM education, and real-world applications. Case studies, group discussions, and brainstorming sessions guide students to apply theoretical concepts in practical ways. Teachers foster creative thinking and exploration at every step.

### **Showcasing Innovation through Assemblies and Science Fairs for Extended Learning**

Our Science in Action Assemblies and Science Fairs are platforms for students to showcase their creativity and extend their learning. We also have **Symposiums** where subject experts and parents from scientific fields share their insights to inspire students and broaden their perspectives. This way, we create a rich learning environment that connects students with real-world professionals.

### **Designing Solutions for Real-World Challenges**

We place a strong emphasis on making education meaningful by connecting what is learned in the classroom to real-world situations. Through projects and field visits, students explore renewable energy, sustainability, and climate change. Design-thinking activities challenge them to develop practical solutions. These initiatives instil values like empathy and a sense of purpose. Our children understand that science is a powerful tool for innovation and a force for positive change.

At Gitanjali Devshala, we prepare students to lead with confidence, innovate, and make a lasting impact on the world.

**Mrs Madhvi Chandra**  
Director and Principal,  
Gitanjali Devshala, Secundrabad

## From the Principal's Desk



I'm Usha Prem, Principal of Chinmaya Vidyalaya, Kolazhy, Thrissur, Kerala. I'm absolutely thrilled that my brilliant team of three have made it to the final round of Macmillan Budding Scientist programme. Their hard work, dedication, and curiosity have paid off.

We believe that instilling scientific temper in our children is essential for their cognitive, emotional, and social growth. By encouraging inquiry-based learning, critical thinking, and creativity, we aim to empower our students to become active participants in the scientific process, equipped to navigate the complexities of our rapidly changing world."

Here are some ways by which scientific acumen is being fostered in students of our Vidyalaya.

### **Curriculum Development**

- Integrate STEM education: Incorporate science, technology, engineering, and mathematics (STEM) into the curriculum.
- Hands-on learning: Encourage practical experiments and activities that promote experiential learning.

### **Teacher Support**

- Professional development: Provide teachers with training and resources to enhance their science teaching skills.

### **Student Engagement**

- Science fairs and competitions: Organize science fairs, quizzes, and competitions to encourage student participation.
- Guest lectures: Invite scientists, engineers, and industry experts to share their experiences and inspire students.

- Science clubs: Establish science clubs or groups that focus on specific areas, such as robotics, astronomy, or environmental science.

### **Infrastructure and Resources**

- Well-equipped laboratories: Ensure that science laboratories are well-equipped and safe for students.
- Technology integration: Incorporate technology, such as simulations, models, and educational software, to enhance science learning.
- Library resources: Provide access to science-related books, journals, and online resources.

### **Community Involvement**

- Partnerships with industries: Collaborate with local industries, research institutions, and universities to provide students with real-world experiences.

### **Assessment and Evaluation**

- Assessment strategies: Develop assessment strategies that evaluate students' scientific knowledge, skills, and attitudes.
- Feedback mechanisms: Establish feedback mechanisms to identify areas for improvement and provide support to students.

These initiatives empower our students to thrive in an increasingly complex technological world.

**Ms. Usha Prem,**  
Principal,  
Chinmaya Vidyalaya, Kolazhy, Thrissur, Kerala

## From the Principal's Desk



“As the Principal of IES Public School, Chittilappilly, Thrissur, Kerala, I am beaming with pride! Our institution is dedicated to nurturing the talents of our students, providing them with numerous opportunities to shine. We foster scientific excellence by engaging our students in various activities that stimulate their curiosity and creativity. Our ATL Lab and Research Center serve as a hub for innovative experimentation, empowering our students to transform ideas into reality.

Our students have consistently demonstrated their exceptional abilities by participating in various inter-school competitions and events organized by renowned institutions. Their dedication and hard work have yielded impressive results, with numerous prizes and accolades won. Notably, they have published papers in research journals, conducted a successful Digi Fest, and participated in competitions conducted by esteemed organizations such as ISRO and NASA. Recently, we conducted a 2-day satellite-making workshop, showcasing our students' talent, perseverance, and teamwork.

I am thrilled to announce that our students have been shortlisted to participate in the prestigious Budding Scientists Program at IIT Madras, representing the South Zone! This exceptional opportunity is a testament to our students' intellectual curiosity, scientific acumen, and innovative spirit. We are incredibly proud of their achievement and look forward to their exciting journey at IIT Madras!”

I wish you all the best

**Dr. Sujatha Harimohan,**  
Principal,  
IES Public School,  
Chittilappilly, Thrissur, Kerala

## From the Principal's Desk



As we continue to navigate the complexities of the 21st century, it has become increasingly evident that science and technology will play a pivotal role in shaping the future of our nation. At Jay Group of Schools, we recognize the importance of fostering a culture of innovation and experimentation among our students.

### **The Atal Tinkering Lab: A Hub for Innovation**

The Atal Tinkering Lab (ATL) has been a game-changer in our efforts to promote STEM education (Science, Technology, Engineering, and Math) among our students. This state-of-the-art facility provides a platform for our young minds to tinker, experiment, and innovate, using cutting-edge technology such as 3D printers, robotics, and microcontrollers.

### **Fostering a Culture of Innovation**

Through the ATL, our students have been able to explore complex concepts in a hands-on and interactive manner. This has not only deepened their understanding of scientific principles but also instilled in them a sense of curiosity and creativity. By providing our students with the tools and resources they need to innovate, we are empowering them to become the problem-solvers and change-makers of tomorrow.

### **Science and Technology: Preparing Students for the Future**

Science and technology are no longer just subjects in the classroom; they are the building blocks of our modern world. By integrating science and technology into our curriculum, we are preparing our students to navigate the complexities of an increasingly interconnected world.

At Jay Group of Schools, we are committed to provide our students with a world-class education that prepares them for success in the 21st century. The Atal Tinkering Lab and our emphasis on science and technology are just a few examples of how we are working to achieve this goal. By fostering a culture of innovation and experimentation, we are empowering our students to become the leaders and innovators of tomorrow.

**M. Senthilkumar,**

Principal,

Jay Matriculation School, Kitchipaklayam, Salem

## From the Principal's Desk



KLE International school strongly creates a vibrant centre for learning which provides a congenial atmosphere for students to excel academically and develop into ethically strong and morally elevated individuals.

“Fostering Scientific Acumen in school” requires a multi-faceted approach. Here are some strategies to promote scientific literacy and critical thinking among students:

### Curriculum Design

- Inquiry-based learning: Encourage students to explore scientific concepts through hands-on experiments and investigations.
- Interdisciplinary connections: Integrate science with other subjects, such as mathematics, language arts, and social studies.
- Real-world applications: Connect scientific concepts to everyday life and current events.

### Teaching Methods

- Hands-on activities: Incorporate experiments, simulations, and models to illustrate complex scientific concepts.
- Discussion-based learning: Encourage students to engage in scientific debates, discussions, and problem-solving activities.
- Mentorship: Pair students with scientists, engineers, or mentors who can provide guidance and inspiration.

### Assessment and Evaluation

- Performance tasks: Assess students’ scientific knowledge and skills through hands-on activities and projects.
- Peer review: Encourage students to review and provide feedback on each other’s work.

- Self-assessment: Help students develop metacognitive skills by reflecting on their own learning and progress.

### **Resources and Infrastructure**

- Well-equipped laboratories: Provide students with access to modern scientific equipment and technology.
- Digital resources: Utilize online platforms, simulations, and educational software to enhance scientific learning.
- Guest lectures: Invite scientists and experts to share their knowledge and experiences with students.

### **Teacher Professional Development**

- Workshops and training: Provide teachers with ongoing professional development opportunities to enhance their scientific knowledge and pedagogical skills.
- Collaboration: Encourage teachers to collaborate with colleagues and scientists to develop innovative lesson plans and activities.
- Mentorship: Pair teachers with experienced educators or scientists who can provide guidance and support.

### **Community Engagement**

- **Science fairs:** Organize science fairs and exhibitions to showcase students' scientific projects and achievements.
- **Partnerships:** Collaborate with local industries, universities, and research institutions to provide students with opportunities for scientific exploration and discovery.
- **Parental involvement:** Engage parents and guardians in scientific activities and events to promote a culture of scientific literacy and enthusiasm.

By implementing these strategies, in our school we foster a culture of scientific acumen, preparing students for success in an increasingly complex and technologically driven world.

**Ms. Dipti Ingley,**  
Principal,  
Kles' International School,  
Bangalore

## From the Principal's Desk



There are only three ways to make a country wealthy – “to dig something up”, “to grow something” or “to create something”.

We are happy and thankful for selecting our School team for the Zonal round from the South Zone for the Macmillan Budding Scientist 2024-2025. Science encourage Curiosity. It invites students to question, explore and seek answers to the mysteries of the Universe. This curiosity, in turn, fosters critical thinking skills.

We give ample opportunities for our students to do practical experiments related to their topics of science subjects studied in the classrooms. We conduct theme based Science exhibitions which gives our students to explore and exhibit their scientific talents and skills. We selected the project on “Heavy Rain Detector” as we felt this would be useful for the Society.

To build the Students’ Scientific temperament our teachers encourage them to ask more questions and feed their Natural Curiosity and this will also promote their interest in the subject. We conduct Science Quiz which triggers the students’ interest and inquisitiveness. Quizzing is a mind sport that engage competitors to sharpen their knowledge beyond books.

Team based projects are given to help them to share their ideas and foster their critical thinking skills. Students watch science related videos in our digital classrooms. We have library where they read science related periodicals and journals. We encourage our students with scientific community by inviting professionals to share their experiences and insights. We take our students to Science Museums, Industries, Research Centres, Botanical gardens etc.

Scientific research is the backbone of innovation, driving breakthroughs that transform the world.

**Dolly Vilgi Oommen**

Principal,

St. Mary’s Residential School,  
Pathanspuram, Kollam

## From the Principal's Desk



In today's fast-paced, ever-evolving world, the ability to think critically, solve problems, and innovate is essential for success. At, Summer Fields we believe that developing scientific acumen is not just about understanding theories but about cultivating a mindset that values inquiry, exploration, and continuous learning. In an era driven by technology and innovation, scientific literacy has become a cornerstone for success and progress.

Science is not confined to textbooks or laboratories; it is a way of thinking and approaching the world around us. Our mission is to encourage students to question, experiment, and seek solutions, whether in the classroom, at home, or in the community. By integrating hands-on learning experiences, promoting interdisciplinary collaborations, and fostering a growth mindset, we provide our students with the tools to not only understand science but to contribute to its future.

In our classrooms, science is not confined to textbooks alone. We encourage students to engage in collaborative learning, where teamwork and communication play an integral role in discovering new ideas and solutions. We also emphasize the importance of interdisciplinary learning, where science intersects with mathematics, technology, and the arts, fostering a well-rounded education.

As we continue to invest in modern resources, facilities, and teacher development, our goal is to ensure that every student has the opportunity to thrive in scientific pursuits. By fostering an environment that nurtures inquiry and innovation, we are preparing our students to become the thinkers, problem-solvers, and leaders of tomorrow.

Our Motto is a collaborative effort amongst students, teachers, and parents — to create a future where scientific acumen is not only celebrated but also embraced as the foundation for a brighter world.

Let us continue to inspire our students to see the world through the lens of science — where every question holds the potential for discovery, and every discovery leads to a brighter, more sustainable future.

**Dr. Urmimala Sudhakar**  
Principal,  
Summer Fields School  
Gurugram, Haryana

## From the Principal's Desk



At K. L. International School, we hold the pursuit of scientific knowledge as paramount. Our curriculum has been meticulously redesigned to align with contemporary advancements, seamlessly integrating experiential learning and practical applications. The Science Club (Innovators) and Eco Club (Friends of Earth) foster a spirit of inquiry and independent research, inspiring young minds to challenge conventions and explore uncharted territories.

In partnership with local experts, our students gain first-hand insights into real-world scientific applications. Our state-of-the-art laboratories, equipped with modern instruments, provide an abundant ground for hands-on experimentation and discovery. Complementing this, initiatives such as WM contests, science quizzes, and field excursions offer students

enriching opportunities beyond the classroom, broadening their horizons and deepening their engagement with science.

We are proud to share that our participation in the CBSE Science Exhibition led to national recognition, with a project on extracting activated carbon from onion skins being shortlisted for the national level. Furthermore, I had the honor of receiving the National Award on Teachers' Day in 2023 from the esteemed President of India, Mrs. Droupadi Murmu, acknowledging our relentless efforts toward holistic student development.

To ensure we remain at the forefront of educational excellence, our teaching faculty engages in continuous professional development. Our teachers actively participated in the 10th National Annual Virtual Labs Nodal Centre Coordinator's Meet, reflecting our commitment to a dynamic and evolving learning environment. Additionally, we encourage participation in National and International Science Olympiads, nurturing a spirit of healthy competition while exposing students to global benchmarks of excellence.

With a firm belief in cultivating curiosity, collaborative problem-solving, and innovation, K. L. International School is dedicated to shaping scientifically literate and forward-thinking individuals, equipped to thrive in an increasingly complex and interconnected world.

**Mr. Sudhanshu Shekhar**

Principal,

K. L. International School, Meerut

## From the Principal's Desk



At Spring Dales English School, Kathua, we are committed to fostering scientific curiosity and nurturing the potential of our students to innovate and excel in STEM fields. Our emphasis on hands-on learning and experiential education sets the foundation for young minds to explore real-world challenges and devise innovative solutions.

### **Key Initiatives**

#### **Visits to Premier Institutions/Industries:**

This year, 118 students of 10th, 11th, 12th Students visited IIT Jammu, where they engaged with cutting-edge research, toured advanced laboratories, and interacted with distinguished experts. The students also visited Chenab Textile Mills, Mansar Lake, Municipality (Sewerage Water Assessment), Fish Farm this year. Spring Dales English School signed MOU in December 2024 with Government Degree College for Women (GDCW) Kathua & LPU to promote creativity and innovation in “STEM through workshops/projects and provide career counseling and mentorship to students of both institutions”. These experiences inspire and expose students to the possibilities of STEM careers.

#### **Atal Tinkering Lab (ATL):**

Our state-of-the-art ATL encourages creativity and innovation. Students actively participate in building science projects fostering critical thinking and practical application of science concepts. Our school has been selected as one of the top Eco-Conscious Schools 2024-25 under the Generation Green Campaign under Atal Tinkering Lab.

#### **Mentorship Sessions, Guest Lectures & Activities:**

Regular Sessions such as Design Thinking and Problem Solving, Time and Resource Management, Patent and Copyrights, Generating Ideas, Robotics Workshop etc by experts equip students with essential skills to ideate and execute projects effectively. We have Eco & ATL Club which conducts various STEM activities and Science Exhibitions.

**Prof R. K. Gupta (Retd. HOD Physics,  
Govt. Degree College Kathua)**

Director,  
Spring Dales English School, Kathua

## From the Principal's Desk



At St. Joseph's Convent School, we are deeply committed to providing our students with a well-rounded education that equips them to meet the challenges and opportunities of the future. To achieve this, we have adopted a comprehensive approach that integrates various strategies to ignite curiosity and promote a profound understanding of scientific principles.

We encourage our students to ask questions, conduct experiments, and engage in hands-on activities. A culture of inquiry is fostered in our school, by encouraging students to view every challenge as an opportunity to ask 'why' and 'how,' transforming curiosity into discovery. We also invite professionals from various scientific fields to share their

knowledge and experiences, enriching our students' learning journeys.

Our science teachers play a pivotal role in fostering a scientific attitude among students. With their passion for the subject and dedication to nurturing young minds, they create an environment where learning is exciting and meaningful.

Students regularly engage in group projects, experiments, and presentations, fostering collaborative learning. Our curriculum integrates real-world problem-solving, helping students develop critical thinking and analytical skills that form the foundation of a scientific mindset.

Our school organized Epiphany Alley in the month of October, a celebration of creativity and innovation, where students showcased their scientific ideas and projects. Science carnivals and exhibitions are also held to highlight students' achievements and promote interdisciplinary learning by demonstrating connections between Science, Mathematics, Technology, and Engineering. Our extracurricular science programs provide additional opportunities for students to delve deeper into scientific topics and engage in experiential learning.

By incorporating these diverse methods, we strive to create a dynamic and engaging learning environment that nurtures a passion for science. Our ultimate goal is to empower students with the knowledge and skills they need to excel academically and contribute meaningfully to society.

**Sr. Archana,**  
Principal,  
St. Joseph's Convent School,  
Jalandhar

## From the Principal's Desk



At St. Joseph's Senior Secondary School, Chandigarh, we are deeply committed to nurturing a scientific temper among our students. Our approach to science education is not confined to theoretical learning; instead, we aim to instill curiosity, creativity, and a passion for exploration through hands-on experiences and collaborative projects.

The Annual Science Exhibition stands as a vibrant platform where students showcase innovative models and working prototypes that address real-world challenges. Events like the Science Mela further provide opportunities for students to present their ideas, fostering confidence and a spirit of inquiry.

In our pursuit of inclusive education, we extend our efforts to schools for the visually impaired by sharing student-made models and creating tactile teaching aids. These aids, designed under the expert guidance of our teachers, aim to make the world of science accessible to all learners, regardless of their abilities.

Our students also enthusiastically participate in various inter-school science competitions, broadening their horizons and inspiring them to innovate and think critically. Workshops on model-making and practical experiments are a regular part of their learning journey, encouraging them to delve deeper into the application of scientific concepts.

At St. Joseph's, we firmly believe that science is not just a subject but a way of life. By fostering scientific acumen, we aim to equip our students with the skills and vision to explore, innovate, and contribute meaningfully to society, preparing them to lead in a world driven by discovery and advancement.

**Ms. Monica Chawla**

Principal,  
St. Joseph's Sr. Sec. School,  
Chandigarh

## From the Principal's Desk



Incredible Science! The phrase says it all. Science has always been fascinating and its wonders have incessantly inspired scientists around the world to seek more. Science at its best is an open-minded method of inquiry, not a belief system. At The Manthan School, we understand that education goes beyond textbooks and classrooms; it's about empowering our students with the tools to explore, experiment, and innovate.

As a testament to this, we are immensely proud to share that our talented students have showcased their exceptional scientific acumen in the MacMillan Budding Scientist Competition, organized in collaboration with IIT Delhi. The participating students' innovation and passion have secured them a spot among the top eight schools in the North Zone. We wish them good luck for the Zonal Round. This remarkable triumph highlights Manthan's commitment to nurturing young minds and fostering a culture of scientific inquiry.

The Macmillan Budding Scientist Competition serves as a perfect platform for the inquisitive minds to explore and appreciate the wonders of science, instilling intrigue among the students, fueling their imagination, and inclining them towards scientific reasoning. We wholeheartedly congratulate the winners and are committed to enthusiastically support their passion and endeavors to unleash their creativity and ingenuity.

We, at The Manthan School, empower 21st century students with a scientific mindset that involves cultivating an environment that encourages critical thinking, creativity, and a sheer exuberance for discovery. Our approach integrates hands-on experiments, collaborative projects, and real-world problem-solving scenarios that challenge students to think beyond traditional boundaries. We aim to ignite the spark of curiosity through an array of initiatives, including dynamic science clubs, interactive seminars with experts, and participation in inter-school and national level science events.

Dear students, you are a harbinger of change to society at large, and my heartfelt wishes will always be there for you. Your unwavering commitment and zeal will usher you to the zenith of success and glory. Let's strive for excellence together.

**Poonam Kumar Mendiratta**

Principal

The Manthan School,  
Greater Noida (West)

## From the Principal's Desk



“Fostering scientific acumen in students is an essential part of education, and we at Carmel School, Sadew, Upper Shillong strive to achieve this in various ways. One effective approach is engaging students in project work, both individually and in groups. These projects allow them to explore scientific concepts, solve real-world problems, and work collaboratively to find creative solutions.

Organizing science exhibitions is another way we encourage students to showcase their talents. These events give them a platform to present their innovative ideas, experiments, and discoveries, building confidence and enthusiasm for science.

Additionally, we are also introducing activities such as coding and robotics, which will make learning interactive and fun while preparing students for future technological advancements.

To ensure sustained growth, we also focus on training teachers, enabling them to guide and inspire students effectively. Teachers are encouraged and helped to create inquiry-based learning environments where curiosity and exploration are valued.

By combining these efforts, Carmel aims to create a culture where students develop critical thinking, problem-solving skills, and a love for science. Through hands-on activities and innovative approaches, we strive to nurture the next generation of scientists, engineers, and thinkers, equipping them with the tools they need to succeed in a rapidly evolving world.

**Sr. Hazel A. C. also known as  
(Rita Rithiang Rymbai),**  
Principal,  
Carmel School, Sadew

## From the Principal's Desk



Rooted in the belief that education is not merely about imparting knowledge but fostering a culture of curiosity, creativity, and critical thinking, GD Goenka Signature School stands at the forefront of educational innovation, redefining traditional paradigms and pioneering new approaches to learning. Empowering students by promoting academic excellence in a safe and nurturing environment. Supporting socio-emotional well-being and creating responsible citizens and leaders who are 'Tomorrow's Ready'.

### **Innovations in pedagogy implemented by school:**

Our balanced approach towards providing exposure to a multitude of skill development, hands on training and academics is what helps us ensure 360' development and overall wellbeing of our learners. Mentioned below is a glimpse of our footprints in nurturing our learners in all the realms. We strive to:

- Transform our classrooms into learning spaces that facilitate the quest to know more, to introspect, to imagine, to create, to explore and experience.
- We try to reinvent and rebuild our curriculum and pedagogical practices to rekindle to joy in learning.
- Along with excellence in academics we focus at the 'learning beyond classrooms' that equips our students for success in the real world with a positive approach, growth mindset, decision making, and communication and leadership abilities.
- We focus on 'learning beyond classrooms'.
- We allow our students to explore and experience what they learn. We practice 'Child centered learning' by keeping in mind the individual differences.
- We instruct less and motivate to 'do' more.
- We have adopted flexible curriculum that is inclusive and suits the learning styles of each learner.

- Strategies like ‘Happy assessments’ only allow us to focus more on learning than on evaluation. Innovative Pedagogical practices such as:
  - Guided research
  - Flipped classrooms
  - Project based learning
  - Life skills embedded curriculum.
  - Subject-integrated learning and
  - Art-integrated learning help us provide the best learning experience to each learner suited to their individual styles and needs.

At the heart of GD Goenka Signature’s innovative ethos lies a profound commitment to experiential learning. We believe in the transformative power of learning by doing, where students are not passive recipients of information but active participants in their own educational journey. In keeping with our commitment to innovation, GD Goenka Signature embraces **flipped learning** as a transformative educational approach. By flipping the traditional classroom model, we optimize face-to-face instructional time for **interactive, collaborative activities, discussions, and hands-on exploration. Through pre-recorded lectures, multimedia resources, and online discussions**, students engage with content at their own pace, enabling personalized learning experiences that cater to individual interests, abilities, and learning preferences.

In conclusion, GD Goenka Signature stands as a beacon of educational innovation, inspiring a generation of lifelong learners, innovators, and changemakers. We remain steadfast in our commitment to pushing the boundaries of education, embracing new possibilities, and empowering students to realize their full potential in an ever-changing world.

**Dr. Alpana Baveja,**  
Principal,  
GD Goenka Signature School, Gurugram

## From the Principal's Desk



We extend our heartfelt gratitude to Macmillan for organizing the Macmillan Budding Scientist, which has been an inspiring and innovative platform for our students. This programme has ignited young minds with creativity and enthusiasm, pushing them to explore the exciting world of robotics. The opportunity to participate has fostered a spirit of collaboration, learning, and technological advancement among the students.

The dedicated efforts of the Macmillan organizing team have truly made this event a memorable experience for our students, providing them with the chance to showcase their talents and innovation. It is through such platforms that students are encouraged to think critically, solve complex problems, and develop essential skills for the future.

We sincerely appreciate the valuable platform provided to our students and the inspiration it has generated. Your support in nurturing young talent and advancing education in robotics is commendable. We look forward to more such enriching experiences in the future.

Thank you once again for everything.

**Mrs. Farhat Hasan**  
Principal-Director  
International School ICSE, Patna

## From the Principal's Desk



Kerala Public School, Mango, Jamshedpur, is committed to nurturing scientific acumen among students through various innovative initiatives. The school emphasizes experiential learning and critical thinking to inspire young minds toward science and technology and encourage students to analyze problems, evaluate data, and form evidence-based conclusions.

Hobby classes play a pivotal role in this mission, offering students opportunities to engage in hands-on activities like Incorporate lab experiments and practical sessions where students explore scientific concepts in action.

The school use real-life examples to demonstrate principles (e. g., Newton's laws using motion and force experiments). These classes provide a platform for students to explore scientific concepts beyond textbooks, encouraging curiosity and creativity.

Science exhibitions are another cornerstone of the school's efforts. These exhibitions showcase student projects and models, fostering a deeper understanding of scientific principles while enhancing their presentation and research skills and Encourage students to present their projects, write reports, or create models. Platforms like science fairs, exhibitions, or STEM clubs can provide visibility. Themes such as renewable energy, space exploration, and sustainable development are explored, aligning with contemporary global challenges.

Participation in interschool science competitions and Olympiads is actively encouraged, helping students compete at regional and national levels. These Science competition encourage teamwork through group experiments, discussions, and presentations. These events hone problem-solving abilities and expose students to real-world scientific challenges, fostering a sense of achievement and confidence.

The school also celebrates the contributions of great scientists and their inventions through dedicated events. Activities such as quizzes, debates, and role-plays during events like Science Day or the birthdays of luminaries like C. V. Raman and Albert Einstein inspire students to appreciate the history and impact of scientific discoveries. Webinars for teachers and students conducted time to time.

These initiatives collectively in still a scientific temperament among students, preparing them to be future innovators and leaders. Kerala Public School, Mango, stands as a beacon of progressive education, striving to make science accessible, engaging, and meaningful for its students.

**Mrs. Rupa Ghosh,**  
Principal,  
Kerala Public School Mango

## From the Principal's Desk



Dear Parents, Teachers, Students, and Members of the Macmillan Budding Scientist Community,

As we continue our journey toward educational excellence, it is crucial that we remain forward-thinking and adaptable to the rapid changes occurring in the world around us. In this regard, I am excited to announce an ambitious initiative that will enhance our curriculum, expand the horizons of our students, and prepare them for the opportunities and challenges of the future.

Incorporating Artificial Intelligence (AI) and Robotics into our educational framework will provide our students with cutting-edge knowledge and skills essential for thriving in the 21st century. These technologies are no longer futuristic concepts but are integral to fields ranging from healthcare and engineering to finance and entertainment. Our mission is to not only familiarize our students with these innovations but to immerse them in hands-on, real-world applications that will stimulate their curiosity, critical thinking, and problem-solving abilities.

To facilitate this, we are developing dedicated spaces within the school for students to engage in robotics workshops, coding clubs, and AI-driven learning projects. These hands-on experiences will ignite their passion for science and technology, demonstrating that these fields are not only relevant but also incredibly rewarding.

Furthermore, as AI and Robotics become increasingly intertwined with various industries, it is essential that students learn not only the technical aspects of these fields but also their ethical and societal implications. We will be emphasizing the responsible use of technology and ensuring that students develop a deep understanding of how to use these tools to create positive impact in society.

Our commitment to fostering interest in science goes beyond just introducing new technologies. Throughout the academic year, we will host science fairs, guest lectures from industry experts, and hands-on experiences that demonstrate the power of innovation. We believe that when students see the real-world impact of what they are learning, their curiosity and excitement about science will flourish.

In addition, we will provide opportunities for students to explore the ever-expanding career paths in AI and Robotics. By partnering with local tech companies, universities, and STEM organizations, we will expose our students to a variety of career options and provide them with mentorship from professionals in the field.

The future is bright for our students, and by equipping them with the tools to succeed in emerging technologies, we are ensuring that they will be leaders in innovation, creativity, and problem-solving. The integration of AI and Robotics into our school curriculum is just the beginning of an exciting chapter in our journey, one that will continue to evolve as technology progresses.

I look forward to seeing how our students engage with these new opportunities and grow into the thinkers, creators, and leaders of tomorrow.

Sincerely,

**Mr. John Stephen,**  
Principal,  
La Martiniere for Boys, Kolkata

## From the Principal's Desk



At St. Michael's School for Girls, we are committed to cultivating a deep appreciation for science as an essential tool for understanding and addressing the complexities of the modern world. A robust foundation in scientific thought empowers students to think critically, solve problems creatively, and contribute meaningfully to societal progress. Our approach to science education is holistic and dynamic, emphasizing active engagement and inquiry. By combining theoretical instruction with hands-on experimentation, students explore the principles that govern our natural and technological landscapes. This interdisciplinary methodology – spanning biology, chemistry, physics, and environmental science – ensures students understand the interconnected nature of scientific fields and their impact on the world around them. Experiential learning is central to our curriculum. Through project-based activities, collaborative research, and practical problem-solving exercises, students develop essential skills such as analytical thinking, teamwork, and self-directed inquiry. Field excursions to environmental sites and science centers further enhance their learning experience, allowing them to apply classroom knowledge in real-world contexts.

At St. Michael's, we strive to empower young women to excel as leaders, innovators, and changemakers in STEM fields. By fostering intellectual curiosity, resilience, and a passion for discovery, we prepare our students to navigate the challenges of the 21st century with confidence and creativity. Together, we are shaping a generation ready to make a lasting impact on the world.

**Mrs. Sangeetha Chakravarti,**  
Principal,  
St. Michael's School for Girls, Siliguri

## From the Principal's Desk



“Creativity is the key to success in future, and primary education is where teachers can bring creativity in children at that level.”

At our Academy, we are dedicated to nurture a passion for science and technology among our students that stimulates creativity, curiosity and innovation. One of the main events in the Academy is the Annual Science Exhibition and Seminar, where students showcase their scientific skills and experiments. This event hones their research and presentation skills and instills in them a sense of scientific inquiry from an early age. The event also helps in bringing out the raw talents of the students and to transform their creativity and thinking (innovative ideas) into reality. The teachers of the Academy take keen interest in translating all the processes.

We, at the Academy, aim to instill a love for learning and inquiry, preparing our students to navigate the complexities of an ever-evolving scientific landscape. It is with great pride and appreciation that I acknowledge the exceptional efforts of Macmillan Education on organizing the Macmillan Budding Scientist Program at our school. This invitation has provided our students with a unique platform to engage with science beyond textbooks, encouraging innovation, critical thinking, and problem-solving.

In a world increasingly driven by technological advancements and scientific discovery, such programs are instrumental in equipping young learners with the skills and mindset necessary to excel in the future. By fostering curiosity and a passion for inquiry, Macmillan Education has contributed significantly to the holistic development of our students.

We extend our heartfelt gratitude to Macmillan Education for their unwavering commitment to empowering young minds. This collaboration has made a lasting impact, and we look forward to continuing this partnership to nurture the next generation.

**Joshua Salam,**  
Principal,  
Brighter Academy, Imphal

## From the Principal's Desk



Developing scientific acumen among students is pivotal for nurturing curiosity, critical thinking and innovation. Our school plays a significant role in creating an environment that promotes scientific inquiry and fosters a deep understanding of the world.

### **Interactive Science Curriculum**

An engaging science curriculum is the foundation of fostering scientific acumen. Our school provides an inquiry-based approach that encourages students to ask questions, explore concepts and conduct experiments. Hands-on activities, such as building models, performing laboratory experiments and participating in fieldwork, allow students to apply theoretical knowledge practically. Students participated in activities like know your scientists, shadow puppetry, skit, documentary writing, journal reading on new inventions and life of scientists and diya making related to water holding capacity of soil (types of soil).

### **Dedicated Science Labs**

Equipping schools with well-designed science laboratories ensures that students can explore various scientific phenomena firsthand. Experiments help students to visualise abstract concepts and develop practical skills in observation, data analysis, and problem-solving. In the chemistry laboratory students tested the hardness of water. In the computer laboratory, Students made posters on canva and powerpoint presentations on Cyber Safety and Role of Artificial Intelligence in Cyber Security-Boon or Bane. Students also made two projects on the Internet of Things(Home Automation System) and Artificial Intelligence(Attendance Tracker).

### **Integration of Technology**

Incorporating technology into science education can elevate the learning experience. Virtual laboratories, simulations and educational apps provide students with interactive ways to explore complex concepts. Schools can also leverage tools like AI, robotics and coding platforms to align with modern scientific advancements. Digital presentations are used in smartboards, practical sessions are conducted on Applied Mathematics, Financial Market Management etc.

AI tools like Padlet, Olabs, Canva, Geogebra etc. are being used by our teachers.

### **Encouraging Research and Innovation**

Creating opportunities for students to undertake small research projects fosters independent thinking. Science fairs, innovation contests and exhibitions provide a platform for students to showcase their ideas and inventions, motivating them to think critically and creatively. Our students participated in CBSE Science Exhibition-Waste management. Their model demonstrated waste management and by converting waste into useful products.

### **Co-Curricular Activities**

Clubs such as science clubs, robotics teams and astronomy groups allow students to delve deeper into their scientific interests outside the classroom. Participation in workshops, national competitions, and hackathons enhances their skills and confidence. Our Science and Nature Educational Activity students visited Acharya Jagadish Chandra Bose Indian Botanical Garden to analyse the variety of plant species, including their features, classifications, adaptations.

### **Collaborations and Guest Lectures**

Partnering with research organizations, universities and industries gives students exposure to real-world scientific applications. Guest lectures by scientists, engineers and researchers inspire students and provide insights into various scientific careers. Our students joined Space Odyssey Camp which provided a spectacular and unforgettable journey through the Solar System that included an introduction to the all-important Electromagnetic Spectrum. It was hosted by international STEAM Outreach Specialist Mr. Sam Gibbs who is deeply committed to encouraging the next generation of young scientists, engineers and professionals in their career pathways.

### **Promoting Environmental Awareness**

Schools can encourage environmental science through activities like eco-projects, tree plantation drives, and recycling campaigns. Such initiatives teach students to apply scientific principles to solve real-world problems, particularly in sustainability. Our students visited Acharya Jagadish Chandra Bose Indian Botanical Garden where they were exposed to a wide variety of plant species, helping them understand the different parts of the plant and how they contribute to a variety of sources of food.

### **Fostering a Culture of Curiosity**

Teachers play a crucial role in fostering scientific acumen by encouraging students to ask questions, think critically and remain curious. A supportive environment where mistakes are viewed as learning opportunities helps students explore without fear. Students participated in soap making activity on bagless day by using stearic acid, sodium hydroxide, coconut oil, perfume and colours.

By adopting these strategies, schools can cultivate a generation of scientifically literate individuals who are well-prepared to innovate, solve problems and contribute meaningfully to society. The goal is to inspire a lifelong passion for discovery and learning in every student.

**Mrs. Koeli Dey,  
Principal,  
Sushila Birla Girls' School, Kolkata**

## From the Principal's Desk



We are all aware that scientific curiosity and reasoning are extremely important in education, and that is something we strive for at Vandy International School. In a world where changes are constant, it is crucial for our students to learn how to think analytically, critically, and innovatively in order to overcome future obstacles.

The philosophy we adopt considers our students' inquisitive nature and assists them in critical thinking. The use of computers in hands-on lab experiences coupled with the use of cutting-edge technology allows students to understand science in a more engaging and stimulating manner.

We are conveniently incorporating AI software, robotics and 3D design into our class curriculum in order to encourage students to be more of forward thinkers. Furthermore, it encourages creativity and collaboration amongst students through science clubs, workshops and nationwide and worldwide scientific fairs.

Our aim is to encourage every student to become a critical thinker and a problem solver, which is why our teachers are extremely focused on every student's development. Through STEM tasks, environmental initiatives, and research, we inspire students to utilize their inventiveness and accountability in solving societal issues through the application of science.

We, at Vandy International School, are dedicated to ensuring that the students of today become the scientists and inventors of tomorrow.

**Ajanita Hazarika**

Principal

Vandy International School, Guwahati

## From the Principal's Desk



It gives us immense pleasure to announce that our student-led team has been selected for the zonal round of the Macmillan Budding Scientist 2024-2025 with their innovative project on the Garbage Robot. Competing against over 1,200 teams from the Middle East zone and securing a spot among the top 10 finalists is a remarkable achievement, especially for a school just established in 2023.

This accomplishment serves as a tremendous source of encouragement for our students, showcasing their hard work, ingenuity, and determination. We owe this success to the guidance and support of the Ministry of Education in the UAE, which fosters an environment that encourages innovation, creativity, and entrepreneurship across all grade levels. Our curriculum emphasizes critical thinking and problem-solving from an early age, ensuring students develop a scientific temperament that prepares them for real-world challenges.

In our innovative learning environment, we promote scientific literacy through engaging initiatives like curiosity corners and STEAM Labs. Students from Kindergarten onwards explore the practical applications of science, enhancing their lateral thinking skills and inspiring them to pursue their passions.

We extend our heartfelt gratitude to Macmillan for their Budding Scientist program, which provides invaluable platforms for young minds to showcase their talents. A special thank you to our dedicated science teachers and supportive parents, whose encouragement propels our students to reach new heights. Let us celebrate this achievement together and continue to inspire our young scientists to explore, innovate, and excel!

**Ms. Joyeeta Bhattacharya,**

Principal,

Woodlem Park School Hamidiya, Ajman

## From the Principal's Desk

At Springdales School, students begin developing essential scientific skills from the earliest years in Kindergarten. Our science curriculum emphasizes both the knowledge of core scientific concepts and the practical application of scientific inquiry. Students engage in hands-on experiments and real-world learning experiences that make science meaningful and relevant to their lives.

Throughout the school, science lessons are enriched by cross-curricular connections, including STEM (Science, Technology, Engineering, and Mathematics) initiatives and sustainability projects. These interdisciplinary approaches help students see the impact of science beyond the classroom and inspire a deeper understanding of the world around them. Critical thinking and problem-solving are integral to our science education at every stage. By encouraging students to ask questions, analyse information, and propose solutions, we foster the development of essential 21st-century skills that prepare them for future challenges. Our goal is to nurture curious, confident learners who see science as a vital tool for understanding and improving the world.

In every phase of their education, Springdales students are empowered to become independent thinkers and innovative problem-solvers, ensuring that science is not only a subject they study but also a lens through which they interpret their world.

**Mr David,**  
Principal,  
Springdales Dubai School

## From the Principal's Desk



In today's fast-evolving world, fostering innovation is vital for children's success. To nurture scientific thinking, curiosity, and a passion for innovation, schools must provide opportunities for exploration and experimentation. At Indian School Sohar in Oman, we strive to inspire students to explore new ideas and push boundaries.

We offer a variety of hands-on activities where students build models, conduct science experiments, and design products. Our science labs cater to primary, middle, and senior students, ensuring resources are available for every age group.

Beyond traditional science education, we recognize the importance of creativity in driving innovation. Our teachers encourage students to think outside the box, find unique solutions, and express themselves through art, music, and writing. This creative freedom helps children develop an innovative mindset.

Collaboration is crucial in innovation. Competitions like those organized by Macmillan allow our students to work in teams, share ideas, and tackle challenges together. Teamwork fosters cooperation and teaches students how to solve complex problems as a group.

Our dedicated team helps students identify real-world problems and come up with practical solutions. By posing open-ended questions and providing opportunities for experimentation, our teachers cultivate a problem-solving mindset. We celebrate achievements, big or small, to build confidence and inspire further innovation.

In line with our commitment to cutting-edge education, we've recently added an AI and Robotics lab to enhance our science and technology curriculum. Our STEAM lab for students in classes III-V is already operational, providing dynamic hands-on learning in science, technology, engineering, arts, and mathematics.

At Indian School Sohar, we are proud to equip students to become tomorrow's innovators.

**Ms. Sanchita Verma,**  
Principal,  
Indian School Sohar, Sohar, Oman

## From the Principal's Desk



It is a proud moment for Aspire Indian International School as our students won the prestigious Macmillan Budding Scientist Award among 600+ teams from GCC securing 5th rank globally last time and continuing mightily this time as well. AIIS is one of the shortlisted teams of the Middle East Zone for 2024-25. This achievement reflects our unwavering motto of 'Igniting Young Minds' and integrating sustainability and development goals into the curriculum.

Our students showcased exceptional passion for research, creativity, consistent improvement and meticulous documentation embodying the spirit of innovation, resilience and teamwork. The unwavering support of progressive parents and the guidance of dedicated teachers who form the backbone of such successes made this possible.

We are determined to take the goals of a sustainable future head-on by fostering critical thinking, environmental responsibility and global awareness. By encouraging students to innovate and address real-world challenges, we aim to empower them to be changemakers who contribute meaningfully to a sustainable and equitable future for all.

**Dr. Geetika Ahuja**

Principal,

Aspire Indian International School, Kuwait

## From the Principal's Desk



Abu Dhabi Indian School places a strong emphasis on fostering inquiry-based learning and real-life applications to nurture scientific acumen among its students. The school believes in inspiring curiosity and encouraging students to ask questions, investigate, and explore concepts beyond textbooks. By integrating inquiry-based approaches into the curriculum, students are empowered to develop critical thinking, problem-solving, and analytical skills.

Well-equipped science laboratories serve as hubs where students can explore concepts practically, deepening their understanding of theories through experimentation.

To further encourage innovation, schools organize science fairs, workshops, and field trips. These events inspire students to think creatively and connect classroom learning with real-world applications. During the Block period Students perform Hands-On experiments and activities which allow them to reinforce theoretical knowledge and make Science more engaging.

Incorporating STEM (Science, Technology, Engineering, and Mathematics) education in the curriculum helps students develop skills like problem-solving, logical reasoning, and analytical thinking, which are critical for scientific pursuits and to take part for external competitions like Formula Ethara-Yas in School Abudhabi UAE, Al Tasamuh conducted by Global Indian International School Abu Dhabi, AI and Robotics competitions, IIC Science Expo, UAE Innovation Exhibition etc.

Collaborative projects and research-oriented assignments provide opportunities for teamwork and in-depth exploration of topics, fostering a scientific mindset. Participation in science competitions and exhibitions helps students build confidence and refine their skills while receiving recognition for their efforts.

Additionally, schools can leverage technology, such as simulations, virtual labs, and AI-based tools, to make science more interactive and engaging. By integrating sustainable practices and current global issues our schools instil a sense of responsibility and a drive to find solutions to pressing challenges. Through these efforts, our schools cultivate a generation of critical thinkers and innovators who are well-prepared to contribute to a scientifically advanced future.

**Mr. Neeraj Bhargava**  
Principal  
Abudhabi Indian School

# Macmillan Budding Scientist, powered by Springer Nature 2024-25

## Finalists:

1. **School Name:** Navrachana Higher Secondary School,  
Sama Vadodara

**Winner:** Grand Finale and **Runner Up:** West Zone

**Students:** Aanshi Sheth, Sreehari Sreejesh, and Dhyana Brahmhatt

**Project Supervisor:** Ms. Sudha Naddi

**Project Name:** Jal Hi Jeevan

Scan the code to  
watch the video  
of the project



## A Design Thinking Approach

Mineral deficiencies are a prevalent issue around the world affecting millions worldwide and deteriorating their health. The poor are the most affected. Having no economic stability, getting mineralised water will not be their priority. But what they are unaware of is that several problems that they face such as joint pains, backaches, fatigue, etc. are all symptoms of taking demineralised water. It is difficult for them to have a high-mineral diet because of their condition but this can be compensated by providing mineralised water.

### Step 1: Empathise:

- These problems have been confirmed by an online survey conducted by our team to know the condition of the masses. 40% of people have a mineral deficiency, 69.9% have a RO TDS that is not up to the mark and yet, only 31.6% are willing to switch to a cheaper, remineralising RO.
- This problem has also been affirmed by people living in slums who have several mineral deficiencies. The survey also confirmed the lack of awareness regarding the importance of consuming mineralised water and how it affects our health.

### Step 2: Define: Inadequate supply of mineralised water

### Step 3 - Ideate:

- We pooled many solutions including Himalayan salt and Alkaline Water Pitchers, but these did not turn out to be ideal due to either effectiveness or cost.
- Solving mineral deficiencies can be solved using a combination of Activated charcoal and kelp.

- These are natural products that will add minerals such as calcium, B12, fluoride, potassium, magnesium sodium and trace minerals such as iron, manganese and zinc.
- These two are sustainable, eco-friendly, effective and cheap and can remineralize our RO water. These are easily available and produced naturally in villages. They are clean and can increase the TDS (total dissolved salts) in water proving to be extremely helpful for fulfilling our mineral needs.

#### Step 4 - Prototype:

- We created a prototype and incorporated these as cartridges and dispensers in our existing RO system which could help in remineralizing the RO water with activated charcoal and kelp.
- Activated charcoal has a porous structure which causes ion exchange and adsorption of toxins and gases. Kelp acts as a semi-permeable membrane which causes minerals to get released.

#### Step 5 - Test

We are in the process of testing. The Arduino coded dispenser is still in the process of making. We will combine the components once our prototype is complete.

#### Sustainability - Taking steps for a healthier water future:

- #3 - Good health and well-being: tackling the prominent issue of mineral deficiencies by remineralizing water.
- #6 - Clean water and sanitation: Providing mineralized water even to the underprivileged in the country.
- #12 - Responsible consumption and production: Spreading awareness about the mineral content needed in water and making people conscious about their water consumption patterns.
- #7 - Affordable and clean energy: Making the product eco-friendly and cost-effective to make it available to all populations in our country.

2. **School Name:** Summer Fields School, Gurugram

**Runner Up:** Grand Finale and **Runner Up:** North Zone

**Students:** Namish Dawar, Yuvraj Sharma and Ayushman Pattanaik

**Project Supervisor:** Ms. Poonam Anand

**Project Name:** Synthetic Polliniser

Scan the code to  
watch the video  
of the project



The Synthetic Polliniser, is an innovative project aimed at addressing the decline in natural pollinators, such as bees, by using artificial means to ensure crop pollination. This is achieved through the use of fiber glass robotic petals that mimic real flowers. These robotic flowers are equipped with pollen dispenser which distributes pollen and lemon grass oil as fragrance to attract and support bees.

### Significance

1. **Support for Declining Bee Populations:** The project addresses the global decline in bee populations due to factors like pesticides, habitat loss, and climate change. By providing a reliable source of pollen and nectar, it helps sustain bee populations and ensures continued pollination of crops.
2. **Enhanced Food Security:** By improving pollination efficiency, the Synthetic Polliniser can lead to higher crop yields, contributing to global food security.
3. **Sustainability:** The project offers a sustainable alternative to natural pollinators, which are increasingly threatened by environmental challenges.

### Uniqueness

1. **Innovative Design:** The use of fiber glass robotic flowers that mimic real flowers is a novel approach to artificial pollination. These robotic flowers are equipped with pollen dispenser and lemon grass oil, attracting bees as if they were real plants. The lid of the pollen dispenser as per requirement if any bad weather condition prevails.

### Concept

1. The project combines principles of robotics, biomimicry, and ecology to create a sustainable solution for pollination challenges.
2. The robotic flowers are designed to closely resemble real flowers, with fiber glass as petals. This design tricks bees into thinking they are real flowers, encouraging them to land and pollinate.
3. The Synthetic Polliniser can be placed alongside real crops, creating a specialized environment that supports bees and helps maintain their population.

## Experimental Design

**Mechanical Setup:** This consists of an artificial flower made up of fiber glass with pollen and a smell humidifier in the middle. Fragrance to be put on the artificial flower to attract bees. The humidifier releases the fragrance in the form of vapor from which bees are attracted. They sit on the flower and pollen sticks on their body hairs. They will fly away with pollens and sit on other flowers.

Synthetic pollenizers offer a sustainable alternative to natural pollinators, which are often affected by factors like habitat loss and climate change. This helps ensure consistent pollination even in challenging environmental conditions.

Overall, the results of synthetic pollinisers have demonstrated their potential to revolutionize agriculture by providing a reliable and sustainable solution to pollination challenges. In conclusion, Synthetic pollenizer is a concept to aid artificial pollination to encourage bees to forage. In our project we are building an artificial pollen dispensing robot. It is an artificial flower which dispenses pollen grains at pollinators which help the flower to pollinate. These steps help ensure that synthetic pollenizers are effective and can be integrated into agricultural practices to improve crop yields and support declining bee populations.

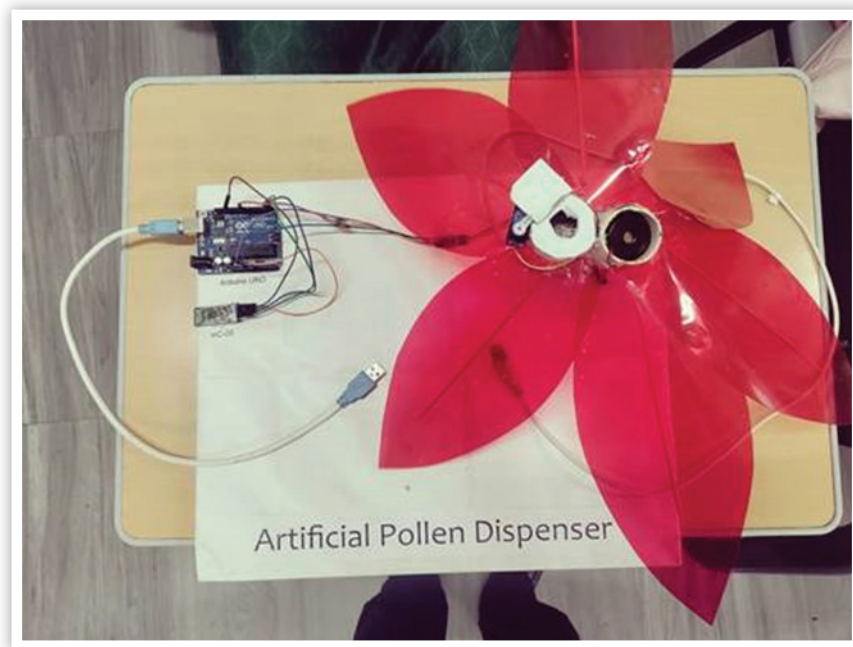

### 3. **School Name:** The Jain International School, Nagpur

**Winner:** West Zone

**Students:** Mast Akshit Jagam, Miss Yayati Gurharikar, and Mast Akshat Mahule

**Project Supervisor:** Ms. Ritu Sharma

**Project Name:** Automatic Fire Control System for Electric Vehicles

Scan the code to watch the video of the project



**Rationale:** Electric vehicles (EVs) are becoming more popular due to their environmental benefits. However, they come with certain risks, one of which is the potential for battery fires. These fires can be dangerous and difficult to control due to the high energy density of the batteries. So to solve this problem, we have made an automatic system that detects and extinguishes fires in electric vehicles for the safety of the driver and the vehicle.

**A few sentences explaining the need of work:** In our neighbourhood, we have observed two incidents where electric vehicles (two wheeler) caught fire while parked outside the house. We often see similar reports in the news about the incidents of electric vehicles catching fire. On an average one electric vehicle catches fire in a month. It leads to loss of money and resources, causes environmental pollution and it is dangerous for the driver also. We went to the electric vehicles showrooms and service centres to find out the reasons for the electric vehicles catching fire. The main cause was the batteries. Due to overheating of batteries, due to faulty batteries these fires were caused. So we thought of making a model which can prevent these incidents caused due to the problems related to the batteries.

**Scientific Principle(s)/ Concepts:** A Project, based upon collection of real – time data and the processing of the data gathered by the use of a microcontroller and giving commands to the motors and other parts of the circuit as per the data received.

**Materials Used:** Micro Controller, IC Regulator, Driver IC, Capacitors, LCD, Flame Sensor, Smoke sensor, Temperature sensor, Motor (12V), Servo motor, Fire extinguishing liquid, Blue tooth module, GSM module, Wood, Wires.

#### **Procedure/ Description:**

In our model, we are supplying 12 volts to the circuit as we are using a motor which needs 12 volts to function. But the microcontroller Arduino V2 (ATMEGA328) which may be considered to be the nucleus of the whole system, works on 5V, so we have used a regulator IC that converts 12V into 5V so that the circuit works properly. The Arduino after receiving the signals from the smoke sensor, flame sensor and temperature sensor displays the information on the LCD display (speedometer console of the vehicle) and if it goes beyond the threshold, an alert (beep sound) is produced and the microcontroller gives command to the motors accordingly.

We cannot control a 12V motor through Arduino, so to operate the motor through the Arduino, we are using a motor driver which amplifies the 5V coming from the Arduino into 12V and also amplifies current from 20Milliamperes to 2 Amperes. The motor driver also controls the direction of the motor.

We established a closed loop feedback system with microcontroller which senses the smoke using the Smoke sensor, flame using Flame detector sensor, Temperature using the temperature sensor and sends the signals to the Servo motor to change the direction of the nozzle of the pipe.

When smoke, temperature is detected above the threshold or a flame is detected the microcontroller directs the motor driver to rotate the shaft of the motor clockwise. The shaft and the screw moves downwards to press the piston of the extinguisher and the foam (fire extinguishing foam) is sprayed. Then it rotates anticlockwise, the shaft and the screw go up and releases the piston of the fire extinguisher.

The foam is not continuously purged, it is done for two seconds, then it stops, so that the excessive usage of extinguishing liquid can be saved. After two seconds if the smoke, temperature or fire is detected, the purging is done again.

If the **Smoke sensor** detects the value above 50 ppm, a beep sound is produced and the microcontroller gives command to the motor to rotate clockwise to press the piston of the fire extinguisher to spray the fire extinguishing liquid in the battery box in all the directions to stop the fire due to which smoke is produced.

If the smoke sensor detects the value below 50 ppm, then no operation will be performed.

The **Flame sensor** used is infrared sensor, if the wavelength detected by the flame sensor is more than 600nm. The sensor sends the message to the microcontroller and the microcontroller finds out on which side of the battery box the flame is produced and accordingly directs the motor to do the purging in a particular direction by directing the servomotor to move the nozzle of the pipe in the direction, the flame has been detected and the fire is extinguished.

The **Temperature sensor (NTC)** senses the temperature. If the temperature sensor senses the temperature above 55 degree celsius, a beep sound is produced to alert the driver and the extinguishing liquid is sprayed in all the directions in the battery box.

A **GSM module** has been attached in the circuit. The GSM module will send the live data of different parameters (Flame detected or not, values of temperature, smoke and voltage) on IOT server (ThingSpeak) after every 30 seconds. You can also get the data on your devices through an app called ThingShow.

If the driver is away from the vehicle and he notices smoke or fire in the vehicle he can activate the automatic fire extinguishing system from his mobile using an app **BLUE TOOTH ELECTRONICS**.

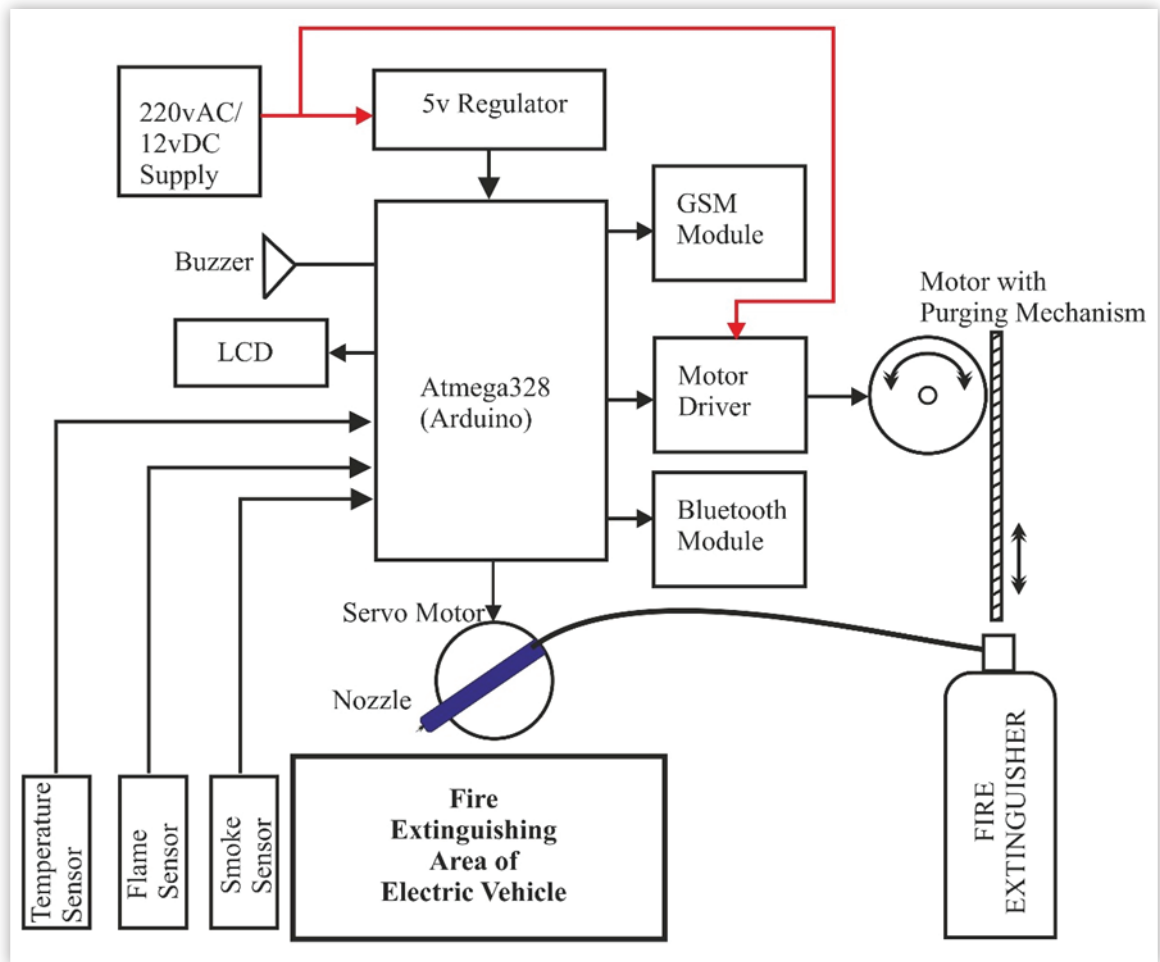

**Hypothesis:** Once the model is mobilized for the masses, the immediate benefit would be that the vehicle and the driver could be saved.

**Data Analysis:** The data will be shown on your mobile devices through an app called Blue Tooth Electronics and on the speedometer console of the vehicle. The GSM module will send the live data on IOT server (ThingSpeak) after every 30 seconds. You can also get the data on your devices through an app called Thing Show.

**Results:** By using this model, we can significantly improve safety of the driver and the vehicle by providing an immediate response to fire hazards. As electric vehicles continue to evolve, integrating such safety features will be crucial in ensuring that they remain a safe and sustainable mode of transportation.

By using this model, we can achieve several **Sustainable Goals**.

1. **Good health and well being:** Since the EV vehicles won't catch fire, we can ensure the safety of passengers and the vehicle.
2. **Affordable and clean energy:** As an electric vehicle runs on battery, it does not cause pollution.
3. **Decent work and economic growth:** The cost of manufacturing new EV two wheelers could be reduced as this system prevents their burning.
4. **Industry, innovation and infrastructure:** This system is innovative and beneficial for the industry since it prevents fires in electric vehicles and does not require manual intervention.
5. **Sustainable cities and communities:** This model will save the passengers and the vehicles, so the cities and communities will be sustainable in long run.
6. **Climate action:** Using this system we can prevent burning and reduce pollution of the air and thus help in reducing carbon footprints.

4. **School Name:** St. Jospeh's Convent School, Jalandhar

**Winner:** North Zone

**Students:** Avreen Kaur, Jaanvi Jain, and Aaradhya Dewan

**Project Supervisor:** Ms. Gurpreet Kaur

**Project Name:** Agrigenius

Scan the code to  
watch the video  
of the project



Sustainable farming is not just about preserving resources, but about innovating for a better tomorrow. It is a revolutionary solution that integrates advanced technology with eco-friendly practices addressing the critical challenges faced by farmers. Developed on the basis of extensive surveys with farmers and agricultural experts, Agrigenius aims to combat pressing issues while fostering sustainable practices.

### Key Problems:

**Water Scarcity:** The world is facing an alarming water crisis, with the prediction that future conflicts may arise over this precious resource. Rivers are drying up, fertile lands are turning into deserts. The agricultural sector, heavily reliant on water for crop irrigation, is particularly vulnerable to this crisis.

**Energy Inefficiency in Agriculture:** In India, farmers face severe challenges with electricity, a crucial resource for running irrigation pumps. Despite the fact that electricity is subsidized by the government, it is often unreliable. Farmers experience frequent power outages, particularly during critical periods when irrigation is most needed.

**Wildlife Damage to Crops:** Crop damage caused by wild animals is another significant challenge, particularly in areas near wildlife reserves. Reports show that up to 71% of households near reserves experience crop losses due to animal intrusions. This issue is not restricted to just a few regions; it affects farmers worldwide, leading to severe economic setbacks.

### Solution:

#### 360-Degree Rotating Solar Panels

To combat energy inefficiency, Agrigenius introduces 360-degree rotating solar panels that optimize energy capture throughout the day. These solar panels can power irrigation systems, providing farmers with reliable energy, even in remote areas. With government subsidies supporting the integration of solar panels, this solution is both practical and financially accessible.

## Soil Moisture Detection System

Addressing water scarcity, Agrigenius incorporates a soil moisture detection system that conserves water by ensuring precise irrigation. This system monitors soil moisture levels in real time, preventing over-irrigation or water wastage. It allows farmers to use water efficiently, ensuring that every drop counts and that crops receive just the right amount of water.

## Animal-Detecting Buzzer System

The threat of wildlife damaging crops is addressed through an animal-detecting buzzer system. This system uses advanced sensors to detect the presence of animals near the fields and activates a loud buzzing sound to scare them away. The sharp noise is designed to trigger the animals' natural fear response, preventing crop damage without harming the wildlife. This solution fosters coexistence between humans and animals, protecting both the farmers' livelihoods and wildlife.

## The Main Highlight:

Agrigenius also features a mobile app that allows farmers to monitor and control their systems remotely. Through the app, farmers can track moisture levels, receive real-time alerts, and manage irrigation efficiently from the comfort of their homes. This smart, integrated approach empowers farmers to safeguard water resources, optimize energy use, and protect their crops from wildlife damage.

Agrigenius is not just helping farmers today but also securing a better future for tomorrow. We are committed to ensuring that every drop of water is preserved, every farmer is empowered, and the land is respected for generations to come.

5. **School Name:** Gitanjali Devshala, Hyderabad

**Runner Up:** South Zone

**Students:** Ishan Mandala, Pranay Pushkar, and Srihitha Reddy

**Project Supervisor:** Ms. Mahima Khare

**Project Name:** Microbial Visibility Marker (MVM)

Scan the code to  
watch the video  
of the project



Science is not just about innovation—it's about making a difference. “Microbial Visibility Marker: A pledge to secure every bite,” is a scientific initiative driven by the belief that health and well-being begin with what we consume. Ensuring its safety is a commitment to oneself and the future of communities. An idea inspired by a vision, driven by a question that resonates “What if there was a way to know that before the first bite?”



### Concern Statement

Each of us can distinctly recall the times when we have come in contact with food that seemed fresh only to later realize it's spoiled- be it a bar of chocolate or a cup of yoghurt. Microbial contamination and poisoning in packaged food often goes undetected, highlighting the critical need for proactive detection 'before the first bite'. This global dilemma, affecting millions of lives each year, calls for innovative solutions to rephrase food safety standards.

## Fundamental Principle

The Microbial Visibility Marker (MVM) operates on the core principle of bioluminescence, where the enzyme luciferase catalyses the oxidation of the substrate luciferin, in the presence of oxygen and adenosine triphosphate (ATP) molecules, producing light. This reaction, regulated by the luciferin binding protein, stabilizes luciferin until a microbial trigger initiates the process. In nature, these components are organized within specialized compartments called scintillons, where they are stored in an inactive form preventing unwanted reactions under normal conditions.

## Mechanism

This principle is the mechanism we aim to incorporate into our MVM system, where the luciferin-luciferase interaction in the MVMs on food packaging, is triggered by microbial activity. Upon detecting spoilage, the markers emit a visible glow, providing a clear and immediate indication of the presence of pathogens, serving as a powerful tool, preventing consumption of contaminated food.



In line with our current capabilities, we designed our prototype to mimic:

Luciferin	–	Quinine
Luciferase	–	Yeast
LBP	–	Sucrose
Microbial trigger	–	Tonic water (demonstrated effectively using UV light)

### **Making of MVM: From Blueprint to Prototype**

- \*Synthesize luciferin, luciferase and luciferin-binding protein genetically to ensure a consistent, scalable and eco-friendly source of components.
- \*Optimize these components to enhance reactivity to specific microbial triggers and alterations in environmental parameters.
- \*Program the engineered luciferase system into MVMs, our glow sensors.
- \*Integrate MVMs into food packaging, developed to glow in response to microbial activity, enabling detection despite the package barrier.
- \*Validate accuracy and reliability under practical conditions, revolutionizing food safety standards.

### **Innovation in action**

Imagine a world where your food talks to you, warning you that it's no longer safe. That's the world our MVMs make a reality! It's not just MVMs but the core technology itself that holds promise for transformative change across diverse fields.

### **Takeaway**

Our journey with this endeavour is our commitment to give back to society in a meaningful way, driving progress while empowering generations to come.

**6. School Name:** Chettinad Vidyashram, Chennai**Winner:** South Zone**Students:** Harsha Madhav B, Jaswanth B K and Krithika S.**Project Supervisor:** Ms. Rubina Jebamalai**Project Name:** Automatic Angle Corrector for Drill Machine

Scan the code to  
watch the video  
of the project

**Introduction:**

In precision machining and construction, accurate drilling angles are crucial for achieving high quality results. However manual angle adjustments are often time-consuming and prone to human errors leading to compromised structural integrity and increased material wastage. To address these challenges the automatic angle corrector for drill machines offers a solution that enhances efficiency and accuracy in drilling operations.

**Problems caused by improper drilling:**

- Damage to the work piece.
- Uneven holes.
- Injuries to the operator.
- Structural failures.
- Electrical and fire hazards.
- Tool breakage.

**Aim:**

To prevent the problem mentioned above revolutionize drilling practices across small scale industries by providing a Cost effective and user-friendly tool that enhances precision and reliability.

**Materials:**

This project is carried out by.

**Arduino micro controller:**

An Arduino micro controller is a small affordable and versatile device used to control the electronic components. It is programmed using the Arduino integrated development environment which supports a simple C++ based language.

### **MG995 Servo motor:**

This is high speed servo motor it has excellent holding power, fast control response and accurate positioning. This motor can rotate 180°.

### **Power bank:**

A power bank is a portable, rechargeable battery pack designed to provide power to electronic devices. It serves as a convenient power source for powering Arduino boards, sensors, motors or other mobile electronics especially in situations where an external power supply is unavailable.

### **Mini hand drill:**

It is a compact manual tool used for drilling small holes in various materials like wood, plastic and metal. They are lightweight and easy to use.

### **Working:**

The Arduino board sends the job to each part. The rotatory encode constantly monitors the drill and checks for any displacement of the drill from its original position. When the rotary encoder senses a displacement, it sends a signal to the servo motor and makes the servo motor rotate the drill back to its starting position. It turns it in the opposite direction until the drill reaches its original position. when this is achieved it stops rotating.

### **Conclusions:**

- This project functions as an adapter for a hand drill and includes a precision measurement system.
- It is particularly useful in areas where transporting a drill press is difficult as its low-profile design makes it highly portable.
- It is significantly much cheaper than a drill press.
- It is safe for the users.

## 7. School Name: International School ICSE, Patna

**Runner Up:** East Zone

**Students:** Samanyu Sinha, Arya Anusha Singh and Abhiraj Pathak

**Project Supervisor:** Mr. MD Saif Alam

**Project Name:** Game Lux **Lux:** Customizable Arduino-Based Mobile Phone

Scan the code to watch the video of the project



Game Lux demonstrates how basic hardware and innovative software integration can replicate essential features of modern smartphones. With its modular design and focus on usability, it serves as a practical example of STEM learning, fostering creativity and problem-solving skills among students and hobbyists.

### Key Features of Game Lux

- ① **Phone Interface:** A menu-based navigation system offering options like games, image viewing, and basic settings, giving a classic phone experience with touchscreen capabilities.
- ② **Gaming:** Includes interactive games like “Guess the Number,” showcasing touch responsiveness and dynamic gameplay. Plans include expanding to more classic games like Snake and Tic Tac Toe.
- ③ **Image Display:** Supports the display of image formats like JPEG, BMP, and PNG stored on an SD card.

### Hardware Components

1. **Arduino Mega 2560:** The brain of the system, featuring robust I/O capabilities and efficient multitasking.
2. **3. 5-inch TFT Color Screen:** A vivid, touch-enabled interface delivering intuitive interactions.
3. **Power Supply:** A portable, 9V battery or USB-powered system ensuring reliability and ease of use.

## Overcoming Challenges

From managing limited memory and touchscreen calibration to optimizing processing speeds, our journey taught us valuable lessons about hardware-software integration and system efficiency.

## Future Potential

We envision Game Lux evolving into a more advanced system with:

- GSM module integration for calls and SMS.
- Wi-Fi connectivity for basic internet usage.
- Expanded storage for games and media.
- Enhanced UI design for a more modern aesthetic.

## Conclusion

Game Lux is more than a prototype; it is an educational and inspirational tool that highlights the possibilities of DIY innovation. With accessible resources and a creative mindset, this project pushes the boundaries of what basic hardware can achieve.

As we conclude, we leave you with this thought:

*“Innovation isn’t about the tools you have; it’s about the creativity you bring to them.”*

**8. School Name: Carmel School, Sadew, Shillong****Winner:** East Zone**Students:** Eiwandaka B. Lynser, Bashaikupar Marbaniang and Dateishisha Kharbuki**Project Supervisor:** Ms. Nevalean Langstieh**Project Name:** Harvesting fresh water using a fog catcher

Scan the code to  
watch the video  
of the project



In areas without adequate rainfall, people have had to get creative and find other ways to get the water they need. In some places, such as those prone to fog, the air itself can be a source of fresh water. The air around us contains moisture in the form of water vapour. Clouds form when the air temperature gets cool enough that the water in the air starts to condense, which means that the water vapour turns into tiny water droplets. All these tiny water droplets make a cloud visible to us. Fog is a low-hanging cloud that touches the ground. Fog can make it difficult to see very far. Fog can be found in many different parts of the world, including coastal areas, mountains, and deserts. Coastal regions frequently get fog because the warm air of the land meets the cooler air from the ocean right around or just above ground level. When these air layers collide, the water vapour condenses, and fog is created. Thus, fog can be a valuable source of water for people living in these regions. While the collected water may need additional treatment steps to make it clean enough to drink, it can be used immediately for most other purposes. But how can you get water out of the fog? With a fog catcher! A fog catcher is a device made of a mesh material that collects

water droplets from the foggy air. Mesh screens are set up perpendicular to the path of the wind. As the wind carries the fog through the mesh, the water droplets get caught and accumulate on its surface. Once the droplets combine and become big enough, gravity pulls them down the mesh and into containers set up for water collection. Fog catchers are becoming more popular in areas where water scarcity is a problem, and they can provide a sustainable source of clean water.

Through condensation, atmospheric water vapour from the air condenses on cold surfaces into droplets of liquid water known as dew. The phenomenon is most observable on thin, flat, exposed objects including plant leaves and blades of grass. As the exposed surface cools by radiating its heat to the sky, atmospheric moisture condenses at a rate greater than that of which it can evaporate, resulting in the formation of water droplets. The fog collector is made up of three major parts: the frame, the mesh netting, and the trough or basin. The frame supports the mesh netting and can be made from a wide array of materials from stainless steel poles to bamboo. The mesh netting is where the condensation of water droplets appear. It consists of filaments knitted together with small openings, coated with a chemical to increase condensation.

9. **School Name:** Abudhabi Indian School, Muroor, Abudhabi  
**Runner Up:** Middle East Zone  
**Students:** Rishikesh Jayagopal, Mohamed Kasim and Dilshan Ayyanam Veetil  
**Project Supervisor:** Mrs. Sobha Alin  
**Project Name:** Digital **Guardians:** The New Era of RFID Door Lock Technology

Scan the code to watch the video of the project



## DIGITAL GUARDIANS: THE NEW ERA OF RFID TECHNOLOGY

This is our Tech Enhanced: RFID door lock system. This project uses:

- ① Arduino Uno Microcontroller
- ② RFID Reader (RC522)
- ③ RFID Tag
- ④ Servo Motor
- ⑤ Jumper Wires

Power supply (more than 9V) {Will also come included if we are making this a real product}

This is a solution to a lot of home thefts happening around the world. Research shows that a home theft occurs every 30 seconds worldwide. That is also a reason why we made this product. Just imagine how many people lose their valuable possessions. Our product works like the room locks in hotels but this model is more cost-efficient as we want to make the whole world have this kind of technology and make the whole world safe with maximum high security. Also, our product can close its door by itself after 7 seconds whereas hotel rooms have to close and open the door every time. This is automated and minimizes unnecessary door openings. If we are making this into a business and planning to sell the product, we would sell it for 30-50 AED in the UAE and 300-500 INR in India which reflects our understanding of the market because electronic devices are very expensive in some places. Plus, there are a lot of people in the world who need a good and cheap security system because a lot of people have their house doors exposed and open. So, we are trying to make it accessible to everyone. This is also a very compact product and is customizable and this sets us apart and is better than the room locks in hotels. You can add motion sensors, fingerprint sensors, buzzers, LEDs and a lot more. Our main goal is to make home security more accessible to everyone. We can also customize our product for the proper functioning of the door by making the delay of the lock longer to close the door if you have any luggage to carry etc. These require very few tweaks and we are making mobile apps for these small things but it is not necessary and is completely optional as you can make changes in the code by yourself. We have used the Arduino IDE app and extensions are installed such as the SPI extension, which is the Serial Peripheral Interface extension and MFRC522 Extension, which is a key factor required for the connection between the RFID reader and the RFID tag. Each RFID tag has a unique code which makes our door lock systems unbreakable. We can also add colour-coded RFID tags and RFID readers and can place them in various entrances, and this makes it easier for identification. We also have an energy savings calculator as additional information so that we can analyze how much energy you spend along with some tips for energy saving. This is why our product is A GAME CHANGER FOR HOME SECURITY.

**10. School Name:** Indian School Sohar**Winner:** Middle East Zone**Students:** Dhriti Basu, Mekha Manojkumar and Paviksha Hari Prasath**Project Supervisor:** Sudarshan Gupta**Project Name:** RailSafe Barrier

Scan the code to  
watch the video  
of the project



AI is neither good nor evil. It is a tool. It is a technology. It is for us to use.

The number of deaths due to people falling down on railway tracks or trains clashing with people on railway tracks in 2022 is a whopping 21 thousand in India alone. To overcome this problem, we have got an idea. This idea includes a few barriers that are placed at the end of the platform. The barriers operate like boom barriers but are controlled by colour sensors instead. The colour sensors will be placed at the side of a metal frame which will be parallel to the height of the colour patch attached to the side of the train.

The side of the train will have a patch of a specific colour, for example, a shade of red. The colour sensor will detect the shade of red colour, and the barriers or the doors will open, which will otherwise be closed when the train is not there, thus preventing people from falling on the railway tracks or from walking over the railway tracks.

The added advantage of this project is that the colour sensor will be coded to identify only a particular shade of red which will be attached to a particular train. This will make sure the passengers do not force barricades open. This system does not apply for goods trains or cargo trains as this only ensures passenger safety.

We have also used the ultrasonic sensor which works by the principle of ultrasonic sound waves at the second barricade to showcase the difference between the two.

Using colour sensors is more efficient than ultrasonic sensors as it is easier for passengers to force the barricades open by keeping objects or their hand in front of the ultrasonic sensor, which doesn't happen in the case of the colour sensor.

In this model we have used boom barriers just to demonstrate our idea in a simple way. But in reality, it is not feasible or practical to construct the barriers across the entire platform. Instead, we can build compact glass sliding doors which will be placed adjacent to the train doors. These will operate on the basis of the colour sensors too.

Furthermore, we have implemented an object detection security system to identify objects on the tracks. This ensures that trains do not collide with obstacles and helps prevent derailments.

We would like to emphasize that our project is currently a prototype. In a practical implementation, high-tech and more powerful sensors would be used to ensure optimal performance and reliability.

**11. School Name:** Jay Matriculation School, Salem**Students:** Shreenithi E., Niha Muskaan N. and Kavinesh S.**Project Supervisor:** Akila S.**Project Name:** Railway Track Monitoring and Alert System

Scan the code to  
watch the video  
of the project

**Abstract:**

Railway accidents during rainy seasons are a significant concern, resulting in substantial economic losses and casualties. Our project, Railway Tracks Monitoring System (RTMS), aims to address this issue by detecting faults and damages earlier, ensuring the safety of passengers and goods.

**Inspiration:**

The increasing number of railway accidents inspired us to create a system that enhances safety and efficiency. A recent incident in Bihar, where a railway worker lost their life during shunting operations, further motivated us to develop RTMS.

**Purpose:**

The primary purpose of RTMS is to ensure the safety and integrity of railway tracks by identifying faults and damages earlier.

**Live Monitoring System:**

RTMS provides live data about track conditions, leveraging technology to enhance safety and efficiency, reduce human efforts, and provide a safe travel experience for millions of people.

**Working:**

The system uses:

1. IR Sensors: To detect cracks and bends on railway tracks.
2. Camera Surveillance: For real-time video feed.
3. Motion Detection: To identify potential threats.
4. Alert System: To send alerts to railway authorities and train drivers.
5. Ultrasonic Sound: To detect and deter wild animals from the tracks.

**Advantages:**

1. Low Cost: An effective and low-cost model.
2. Real-time Monitoring: Automatic track monitoring data sent to the control room.
3. Reduced Animal Mortality: Minimizes animal mortality due to train accidents.
4. Improved Railway Safety: Enhances overall railway safety with real-time monitoring and alerts.

**Future Scope:**

In the future, we plan to install RTMS in real-time transportation systems, making travel safer and more convenient.

**12. School Name:** Delhi Public School, Nacharam, Hyderabad

**Students:** Koppula Akshath Reddy, Alonipally Devik Krishna Goud, and Rithvik Sai

**Project Supervisor:** Harika

**Project Name:** AI Yoga Trainer

Scan the code to watch the video of the project

**Overview:**

The AI Yoga Trainer is a virtual assistant designed to guide users through yoga exercises using artificial intelligence (AI). Hosted on a platform or website, it provides yoga routines, real-time feedback. The aim is to offer an immersive, adaptive yoga experience without the need for a traditional instructor.

**The Problem:**

Yoga practitioners, whether beginners or experienced, face several common challenges:

1. **Lack of Personalized Guidance:** Traditional yoga classes often don't cater to individual needs, especially for beginners, increasing the risk of injury and hindering progress.
2. **Limited Accessibility:** In-person yoga sessions can be challenging due to location, time constraints, or physical limitations, making it hard for many to practice regularly.
3. **Inconsistent Feedback:** Without real-time corrections, users may perform poses incorrectly, leading to poor posture, reduced effectiveness, and higher injury risks.

**The Solution:**

The AI Yoga Trainer leverages AI, machine learning, and computer vision to address these challenges and offer a personalized yoga experience:

**Real-Time Posture Feedback:** Using computer vision, the AI monitors posture and provides immediate corrections to improve alignment and prevent injuries.

**Progress Tracking:** The AI tracks key metrics like flexibility and strength, providing valuable insights and adjusting routines to optimize progress.

**Key Features:****1. Real-Time Feedback:**

- **Computer Vision:** The AI uses advanced technology to monitor posture and provide immediate corrections.
- **Alignment Corrections:** Instant visual cues and instructions guide users to adjust their posture, helping prevent injury.

**2. Future Enhancements:**

- **Customizable Session Length and Intensity:** Users can adjust session duration and intensity based on their preferences.

- Voice and Visual Assistance: Voice prompts and visual demonstrations guide users through each pose.
- Progress Tracking: The AI tracks flexibility, strength, and balance, with integration of fitness trackers to monitor real-time data such as heart rate.
- Breathing and Meditation Guidance: AI suggests breathing exercises and meditation to complement yoga and enhance mental well-being.
- Accessibility Features: The system offers modified poses for injuries and mobility challenges, with multi-language support.
- Goal Setting: Users can set fitness or wellness goals, and the AI adjusts routines to meet them.
- AI-Driven Yoga Community: An interactive platform for users to share progress and experiences.

### Who Will Benefit:

1. **Beginners:** Those new to yoga can benefit from guided routines that focus on proper form.
2. **Busy Individuals:** The AI Yoga Trainer allows users to practice yoga anytime, anywhere, offering flexibility and convenience.

### System Architecture:

1. **User Interface (UI):** Simple, intuitive design with a dashboard, workout plans, progress tracker, and settings.
2. **AI Engine:**
  - Machine Learning Models: AI algorithms improve based on user feedback and yoga data.
  - Computer Vision: Real-time posture tracking using cameras or wearables.
3. **Backend:** Cloud storage for user data, preferences, and progress, with frequent updates.

### Future Enhancements:

**Wearable Integration:** Real-time adjustments using heart rate monitors.

**Augmented Reality (AR):** Poses demonstrated by AR avatars.

**Social Features:** Share progress within the yoga community.

**AI-Driven Meditation:** Personalized sessions based on emotional state.

**13. School Name:** Chinmaya Vidyalaya, Thrissur**Students:** Nivedita V Dhanayan, Bhadra Anoop and Devaamsh Arun Mampazhy**Project Supervisor:** Babitha S.**Project Name:** Tarani

Scan the code to  
watch the video  
of the project

**Overview**

Time-calculator Assistant for Road-crossing - Arduino-prototype & New-technology Implementation-ideas.

For a pedestrian or even for a vehicle, crossing a road in India can be a challenge many a time. The challenge only gets bigger when the point of crossing is after a curve in the road and the pedestrian gets to see the incoming vehicle only after it negotiates the curve and is about to reach the crossing point. In short, in many cases, it can be a matter of life and death.

The Chinmaya Vidyalaya at Thrissur is at such a location that pedestrians who travel to and from the school encounter such a crossing point. Incoming vehicles come from behind a curve, that too with a slight downward slope, and so despite the zebra crossing, one is often worried about their safety. Perhaps, with time, a foot over bridge or some other solution may be implemented, however for now, we don't have it. Moreover, we know from observation that such crossing points after a curve are common in India and constructing foot over bridges in all those places may not be practical and not senior citizen friendly. As students, together with our mentor teacher, we started thinking what is it that we can do or suggest as a solution.

Various ideas were considered - for example to develop a system for the vehicles to be warned of the presence of pedestrians waiting to cross the road or even a system that can force the vehicle to slow down, however this could perhaps mean implementing systems on all vehicles or methods than could cause inconvenience to vehicles even when there is no one waiting to cross. Displaying live videos of vehicles can be costly and does not give a sense of speed or time, the latter is true with installing mirrors as well. Eventually we zeroed in on a system or device that can give an estimated time that the vehicle will take to reach the crossing point, thereby helping the pedestrian or vehicle wanting to cross the road to make a judgement.

We did a prototype using Arduino and successfully demonstrated it. The beauty of the solution is that it is useful not just for road crossings after a curve, but for similar rail crossings or even for any general (i. e. without a curve) crossing point. Likewise, the output can be communicated in many different ways - like on a display board or as voice or both. If cost is not a factor, a live video combined with the estimated time is also possible.

If appropriate sensors can be found or developed, handheld devices or even incorporating the solution into future smartphones are possible. There may be even more avenues that we have not thought about yet, but the reader can now add on to this.

Technology cannot be a substitute for common sense or caution or road discipline. However, the right mix of technology to the aid of humans can be lifesaving.

**14. School Name:** Kles' International School, Belagavi

**Students:** Md. Khizar Peerzade, Affan Harlapur and Chinmay Methgudmath

**Project Supervisor:** Ruthveena Malannavar

**Project Name:** Smart Bridge

Scan the code to watch the video of the project

**Objective:**

The objective of smart bridges is to improve safety, extend lifespan and optimize maintenance.

**Principle:**

The principle of a smart bridge project is to use advanced monitoring systems and adaptive designs.

- **Pulse Width Modulation (PWM):** The PWM principle is a technique that controls servo motors by varying the width of electrical pulses sent to the motor. PWM creates a series of pulses of varying width that are repeated at a consistent rate. The width of each pulse determines the speed of the servo motor. A potentiometer is a variable resistor that measures the position of a servo motor's shaft and sends feedback to the control circuit.
- **TDR, which stands for "Time Domain Reflectometry,"** is a principle used in soil moisture sensors where a high-frequency electromagnetic pulse is sent through the soil, and the time it takes for the pulse to travel and reflect back is measured, allowing for the calculation of soil moisture content based on the fact that the speed of the pulse is directly related to the soil's dielectric constant, which is largely influenced by its water content; essentially, wetter soil slows down the pulse, resulting in a longer travel time.

**Material Required:**

- **Arduino Uno:** The Arduino Uno is an open-source microcontroller board based on the Microchip ATmega328P microcontroller (MCU) and developed by Arduino. cc and initially started in 2010.
- **Arduino cable:** The Arduino Cable is a type of USB cable designed specifically for the Arduino Uno.
- **2x servo Motor:** A servo motor is a motor that can precisely control the linear or rotational motion of a mechanical system.
- **Soil Moisture sensor:** A soil moisture sensor measures the amount of water in the soil. It can be used to monitor soil moisture levels and schedule irrigation events.
- **Small breadboard:** A breadboard is a plastic board with holes that's used to build and test electronic circuits without soldering.

- Jumper wires: A jumper wire is an electrical wire with connector pins at each end that connects two points without soldering.
- Foam sheet

### Construction Steps:

- Connect the jumper wire to servo motors.
- Connect the water detector sensors to jumper wires.
- Then connect it to Arduino Uno.
- Attach the jumper wires to Arduino Uno with GND pin.
- Connect the servo motors, GND and 5 V wires with breadboard.
- Connect the another wire to Arduino Uno in pin no. 4
- Connect all the jumper wires to the breadboard in a line.
- Connect one water detector sensor wire to the breadboard and another wire to the Arduino Uno pin no. 5.
- Take a foam sheet and make table base and bridge.
- Connect all the materials to the base.

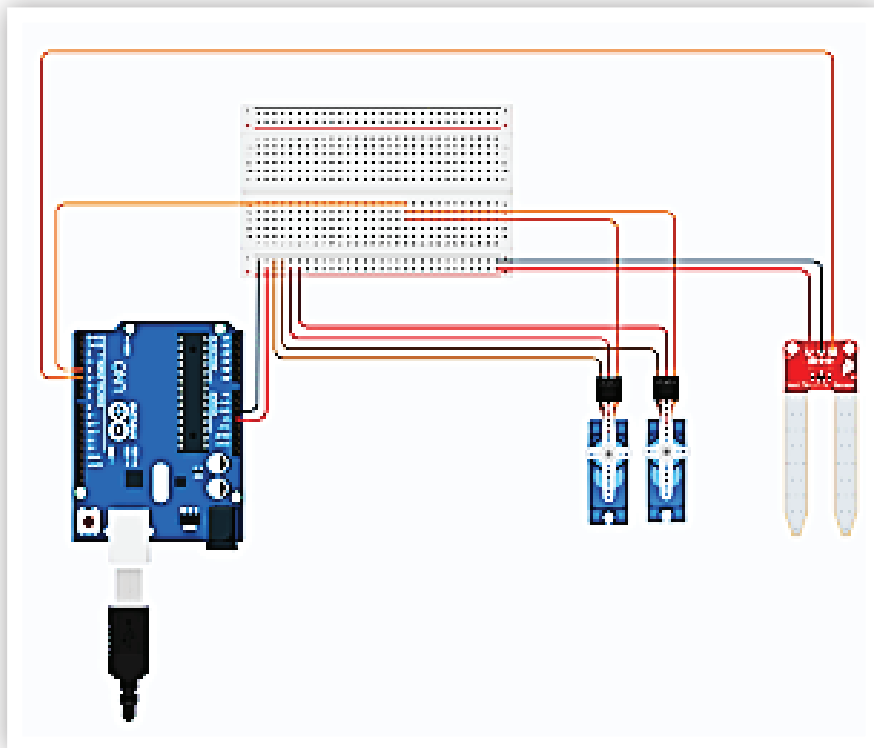

## Coding In Arduino IDE:

```
include <Servo. h> #
define soilpin A1 #
int soil = 0;
Service service1;
Servo servo2;
int on = 90;
int off = 0;
void setup()
{
pinMode(soilpin, INPUT);
servo1. attach(9);
servo2. attach(10);
servo1. write(off);
servo2. write(off);
}
void loop()
{
soil = analogRead(soilpin);
if(soil < 700)
delay(500);
servo1. write(on);
servo2. write(on);
} else
delay(500);
servo1. write(off);
servo2. write(off);
}
```

## Application:

- Flood prevention: This prevents bridge foundations from breaking and keeps traffic moving during floods.
- Safety: The automatic height adjustment system keeps the bridge at a safe height, which prevents accidents and damage.
- Resilience: the system makes bridge more resilient to flooding and climate change.

**15. School Name:** IES Public School, Thrissur**Students:** Farah Febin, Aswathy B. S. and Sreya Baburaj**Project Supervisor:** Rathi A. N.**Project Name:** Sign Language Recognizer

Scan the code to  
watch the video  
of the project



The Sign Language Recognizer is an innovative project designed to bridge the communication gap between the deaf and hearing communities. Utilizing advanced computer vision and narrow AI technologies, this tool recognizes sign language gestures and translates them into English text in real time. It employs a Raspberry Pi 4 (RPi4) as the processing unit, paired with a 7-inch touch display for a user-friendly interface. The software for this project is entirely developed in Python, leveraging its versatility and wide range of libraries.

The primary objective of the project is to enhance accessibility and inclusion for deaf individuals in education, workplaces, public services, and social environments. This technology addresses critical communication challenges by interpreting the shape, movement, and orientation of hand gestures, associating them with their corresponding English translations. The system is trainable and adaptable, accommodating various sign languages and individual signing styles for improved accuracy and usability.

Key applications of the recognizer include its use in educational institutions, where it assists teachers and students in interacting with deaf individuals and serves as a learning tool for sign language students. Public services, such as hospitals and government offices, can implement the technology to ensure equitable access to essential services. In workplaces, the recognizer fosters inclusivity by enabling effortless interaction between deaf employees and their colleagues. Socially, the tool enhances participation in conversations and events, making them more inclusive for deaf individuals.

**16. School Name:** St. Mary's Residential School,  
Pathanspuram, Kollam

**Students:** Aryanath R M, Sreehari A S and Asif S

**Project Supervisor:** Sunitha K Samuel

**Project Name:** Heavy Rain Detector

Scan the code to  
watch the video  
of the project



## Introduction

Climate change refers to the long-term warming of the planet due to an increase in average global temperature, primarily caused by human activities that release green house gases into the atmosphere.

Climate literacy is important to help people understand and become aware of climate change, its causes, effects, and potential solutions. It is also essential that we have the ability to effectively communicate climate change information to others and advocate for climate action. This helps communities to prepare for and respond to climate related disasters and changes.

As a result of varied climatic conditions, Kerala has experienced more intense and erratic rainfall events, which lead to landslides and floods. In 2018, Kerala experienced its worst flood in decades, with over 410 deaths and thousands displaced. A series of landslides has occurred in different villages of Wayanad in 2024.

## Weather Forecasting

Weather forecasts help people prepare for dangerous conditions like storms, floods, and heat waves. In case of such situations, people can stay indoors to avoid unnecessary risks. Rainfall measurements are also equally important in a small state like Kerala for many reasons including – agriculture, flood control urban planning, transportation, water resource management, forecasting, and so on.

## Objective

The aim of the project is to construct a heavy rain detector using rain gauge.

## Rainfall measurement by IMD

The Indian Meteorological Department uses data from over 3700 rain gauges to prepare rainfall statistics in India. The IMD's rainfall categories are:

Condition	mm/day
No rain	0.0
Trace rain	0.01 – 0.04
Very light rain	0.1 – 2.4
Light rain	2.5 – 7.5
Moderate rain	7.6 – 35.5
Rather heavy rain	35.6 – 64.4
Heavy rain	64.5 – 124.4
Very heavy rain	124.5 – 244.4
Extremely heavy rain	Greater than 244.5

The IMD provides rainfall statistics in tabular, map, and geographical formats for the country, states, districts, and other administrative zones. The statistics are available for various temporal scales, including weekly, monthly, seasonal and annual.

## Main Components of Rain Detector

1. Rain Gauge
2. Light Emitting Diode (LED)
3. Buzzer Alarm
4. 9-volt batteries
5. Switch
6. Connecting wires

**17. School Name:** St. Joseph's High School CBSE, Panvel

**Students:** Mst. Mohd Arman Khajatullaman Shaikh and Ms. Carol Jessica A.

**Project Supervisor:** Mrs. Sabira Shaziya Shaikh

**Project Name:** IOT Based Landslide Early Warning System

Scan the code to watch the video of the project



### Problem statement:

Landslides, one of the most devastating natural disasters in hilly areas, cause significant destruction to property, infrastructure, and human life. Triggered by factors such as heavy rainfall, earthquakes, soil erosion, and human activities like construction and mining, landslides have become increasingly frequent in India. Over the past decade, landslides have claimed many lives annually. For example, in August 2021, Maharashtra experienced multiple landslides due to heavy rains, resulting in at least 60 deaths. Similarly, the catastrophic 2013 Uttarakhand disaster claimed 6000 thousands of lives. More recently, in July 2024, a devastating landslide in Kerala's Wayanad district killed more than 300 people. From Figure 1, it is observed that a total of 3,782 landslides occurred between 2015 and 2022, according to information provided in the Lok Sabha by Dr. Jitendra Singh, Minister of State (Independent Charge) for Earth Sciences. These events highlight the urgent need for effective preparedness and safety measures in landslide-prone regions.

The objective of a landslide early warning system is to mitigate these risks through:



**Figure 1** – United Nation Sustainable Development Goals.

Our objective is inspired by several United Nations Sustainable Development Goals (SDGs), including Climate Action, Clean water and Sanitation, and Decent work and Economic growth.

- Real-time data monitoring and collection: Installing moisture sensors on mountains to track soil moisture levels.
- Information sharing: Communicating warnings to authorities like SDMA, IMD, PWD, emergency services, and the public.
- Emergency measures: Ensuring shelters are equipped with essential supplies like medical kits, food, clothing, and lights.

During heavy rainfall, water seeps into the soil and underlying layers, weakening their structure and increasing the likelihood of landslides. To detect this early, moisture sensors can provide real-time data to a monitoring station.

### **Components & Working:**

The main components used in this project are the ESP32, moisture sensors, the Blynk IoT platform, the Arduino IDE, LEDs, and jumper wires. Two moisture sensors are connected to the ESP32 device on pins 34 and 35. The ESP32 comes with built-in Bluetooth and Wi-Fi capabilities. Once the moisture levels detected by the sensors are processed by the ESP32, the data is transferred to the Blynk platform, where the real-time moisture levels are displayed.

If the moisture level exceeds a threshold value, an alarm is activated. For this demonstration, LEDs are used to simulate the alarm system, connected to the ESP32 on pins 4 and 5. This technology enables authorities to respond proactively, potentially preventing loss of life. In situations where sudden landslides leave no time for evacuation, emergency bunkers equipped with medical kits, food, and other essentials can act as life-saving shelters.

### **Conclusion:**

landslide early warning systems play a critical role in reducing disaster risks. By providing timely alerts and enabling efficient resource allocation, these systems can protect communities, save lives, and improve disaster response strategies in vulnerable regions.

### **Future scope:**

- To utilize BHUVAN ( Indian Geo platform of ISRO) data for forecasting for rain forecasting to implement necessary precautionary measures.
- Additionally, to design a rainwater harvesting model that effectively captures and utilizes rainwater.

**18. School Name:** Broadway International School, Surat**Students:** Dirsty Agarwal, Kiara Bhogar and Achhat Sarsahay**Project Supervisor:** Shreya Bhagat**Project Name:** Water Treatment Plant and Drainage Cleaning System

Scan the code to  
watch the video  
of the project



## Scope

Our project can be used to keep our rivers clean to decrease the burden on local bodies and to solve the problem of clogged drainage.

## Problem Statement

As we know that today's major issue is pollution, which is degrading our mother nature. Because of urbanization and industrialization, our water bodies and environment are getting polluted. The pollution of our rivers is caused by industrial factories and the indiscriminate disposal of solid waste. Pollution should never be the price of prosperity. Water clogging is also common because of household waste, so to stop those clogging and to stop river pollution we have made automatic drainage cleaner. It will help us to collect recyclable plastic and will not harm animals. Hypothesis

We have tried to find the reason behind the water pollution. We come to the conclusion that factories and drainage water is degrading the rivers to some extent. So, we tried to find a solution to decrease that. For that we come to the conclusion that every factory needs to clean the water before releasing it into the river. On other hand the water that is being released from drainage should be free from plastic waste. It will help us to keep the rivers clean.

## Objective

The objective of this project is to keep the rivers clean and to reduce the water pollution. As for the comfort of today's generation, we can not compromise with the future of upcoming

generation. It's high time we take strict action to save mother nature. As we have already degraded mother nature to the extreme level.

## Methodology

Our system consists of two main systems, one is the Water Purifying Unit and the second is Automatic Drainage Cleaner. Our first system majorly focuses on factory wastes which is the main reason for water pollution. So to reduce that we have attached a water purifying system to remove solid waste from the waste water of the factory. Our second system mostly focused on clogged drainage. Water clogging is also common because of household waste, so to stop those clogging and to stop river pollution we have made automatic drainage cleaner.

## Procedure

Water Purifying system: Water is collected from the factories and passed through five steps to remove solid particles. First it will pass from stones then from gravels after that from charcoal then from sand and at the end it will pass from cotton. For advancement, we can also fit a carbon filter, chlorination tank and UV treatment to remove soluble impurities. After passing from the purifying system, either you can release or reuse it in the factory. The water purifying system ensures that the water is free from harmful chemicals, bacteria, sediments, heavy metals, and other contaminants.

**19. School Name:** Gaikwad Global School, Chhatrapati Sambhajinagar (Aurangabad)

**Students:** Sairaj Bharat Shinde, Arya Umesh Pardhe and Sarthak Mahesh Thale

**Project Supervisor:** Syed Misbah W.

**Project Name:** Sugar Rocket

Scan the code to watch the video of the project



### Problem Statement:

Fire crackers like rockets are the center of attraction for children during Diwali.

The gunpowder used in these rockets is made up of potassium nitrate, sulphur and charcoal which on combustion produces harmful gases like carbon protoxide, carbon monoxide, Hydric sulphide, Nitrous oxide, etc.

These gases are highly toxic in nature which cause air pollution and can also cause Keratitis, Conjunctivitis, Corneal ulceration & Loss of vision.

Apart from this if the rocket takes a proper trajectory then it goes to the sky or else it may hit anyone causing severe physical injuries and burns or may cause fires in surroundings.

Proposed Solution: To solve this problem we have designed and developed a project "Sugar rocket". The aim behind making this project model is to reduce the environmental and health hazards caused by gunpowder by replacing the rocket fuel with a material from our kitchen i. e. sugar, as it won't produce toxic gases after combustion.

To reduce chances of physical injuries, we have designed a distant ignition system and a simple launcher that gives a proper trajectory to the rocket.

### Methodology:

Our sugar rocket is made up of all pre-used materials like old PVC pipes, cardboard, sawdust and so on.

The rocket is powered with potassium nitrate and sugar in proportions of 65%: 35%.

The ignition system is based on a simple circuit connected to a power source of 3. 7V, controlled by a switch (wired and wireless both). When it is turned on it ignites the matchstick and further the rocket fuel.

The launcher comprises of a steel rod fixed to the ground. The rocket is inserted into the launching rod with the support of PVC ring attached to the body of rocket. When launched the rocket takes a proper direction preventing injuries and the person launching remains at a safe distance too.

**Results:** The sugar rocket launched safely and successfully with a proper trajectory.

## Images:



## Conclusions:

The sugar rocket made by  $\text{KNO}_3$  and sugar mixture has potential environmental advantages in terms of being less toxic and more biodegradable compared to other chemicals, but it should still be used with care.

The potential for environmental harm exists if large quantities are released into ecosystems.

The combustion process still contributes  $\text{CO}_2$ . Therefore, it is most beneficial in carefully controlled and small-scale applications.

## Future Scope:

With improvisation and guided research, the rocket can be made useful for various missions including military operations and unmanned space launches.

## Limitations:

The Carbon dioxide gas produced as a product of combustion needs to be limited.

The used rocket body contains non-biodegradable materials which need to be collected and discarded properly.

Nitrogen compounds in  $\text{KNO}_3$  can lead to eutrophication if mix with water bodies.

**20. School Name:** New Grace English School, Pune

**Students:** Ayesha Ahteshamuddin Shaikh, Rida Ajas Sayyed and Yusra Toufique Sayyed

**Project Supervisor:** Nasreen Mubin Khan

**Project Name:** Innovative Flexible Highway Barrier

Scan the code to watch the video of the project



In today's fast-paced world, road safety is a pressing concern as high-speed collisions on highways often lead to devastating consequences, including loss of lives and extensive property damage. The students of Grade VIII at New Grace English Convent, Pune, have risen to this challenge with their innovative project, the Flexible Highway Barrier—a groundbreaking solution designed to enhance safety and minimize the risks associated with high-speed accidents.

### The Problem with Traditional Barriers

Conventional highway barriers, though widely used, have inherent limitations:

- **Ineffectiveness at High Speeds:** Traditional barriers often fail to stop or slow down vehicles effectively during high-speed collisions.
- **Increased Vehicle Damage:** Their rigid structure exacerbates the impact, leading to severe damage.
- **Higher Risk of Secondary Accidents:** These barriers may cause vehicles to ricochet unpredictably, increasing the risk of further mishaps.

### Our Innovative Solution

The Flexible Highway Barrier addresses these challenges by incorporating advanced engineering concepts that prioritize safety, effectiveness, and innovation.

#### 1. Impact Absorption and Speed Reduction:

- **Dual-Spring Mechanism:** A specialized dual-spring system absorbs and dissipates the energy from collisions, significantly reducing the impact force experienced by both the vehicle and the barrier.
- **Flexible Plate:** The barrier features a fallible plate designed to adjust during impact, ensuring gradual deceleration and minimizing vehicle damage.

#### 2. Controlled Vehicle Redirection:

- **Safe Redirection:** Unlike traditional barriers, our system redirects vehicles back onto the road safely, preventing them from veering into oncoming traffic or causing secondary accidents.

## Benefits of the Flexible Highway Barrier

- **Enhanced Safety:** The design drastically reduces the risk of severe injuries and fatalities by controlling and absorbing the impact of high-speed collisions.
- **Minimized Property Damage:** By cushioning the impact and reducing rebound effects, the system protects vehicles and infrastructure, saving costs on repairs and replacements.
- **Reliable Performance:** The barrier performs effectively under high-speed conditions, making it a dependable safety measure for highways.

## Conclusion

This innovative barrier system represents a significant advancement in highway safety. By integrating flexibility, energy absorption, and controlled vehicle redirection, it addresses the limitations of traditional barriers while offering a practical, cost-effective, and life-saving solution. The dedication and ingenuity of our students—Ayesha Ahteshamuddin Shaikh, Yusra Toufique Sayyed, and Rida Ajaj Shaikh—are evident in this project, which stands as a testament to their commitment to creating a safer world.

**21. School Name:** Sanskar Vidya Sagar school, Nagpur

**Students:** Shrimahi Zhilpe, Chaitanya Pasari and Devansh dudhalkar

**Project Supervisor:** Anjali Bhargava

**Project Name:** Acne Alert

Scan the code to watch the video of the project



### Statement of Problem:

Everyday in the morning all the Adolescents don't dare to see mirror as they are scared to get new pimple/Acne on face and affect their persona. Is there any way to detect early pimples?

### Solution:

Acne Alert is the solution for this problem.

Explanation: We have developed an Acne Alert program. In this one has to see in the camera of Laptop, immediately acne/s are identified and shown in Yellow box with dimensions.

If the marked value is below a certain level and acne is about to spurt so that one can take necessary action.

### Method:

Pimple detection using OpenCV and Convolutional Neural Networks (CNN) involves a combination of image preprocessing and deep learning to identify pimples on facial skin. This includes resizing images to a uniform size, converting them to grayscale. Histogram equalization can enhance contrast, and thresholding or edge detection helps segment skin regions, focusing on areas where pimples are likely to appear.

### Future Research:

We have started working on usage of Acne Alert to detect breast Cancer at very early stages.

### Conclusion:

The use of Acne Alert will prove as a boon for Adolescence and will help for early treatment and safeguard body image.

**22. School Name:** Mithi Gobindram Public School, Bhopal**Students:** Vivan Menghani, Abhinav Verma & Suyash Kriplani**Project Supervisor:** Syed Maqbool Ahmed**Project Name:** Mixer Grinder Without Electricity

Scan the code to  
watch the video  
of the project



This model is based on Electro-magnetic Induction in which the coil containing blade rotates by means of magnetic field and it also rotates the jar attached to it by innovation technique. We can make it useful for the conservation of electric current as it works on magnetic field.

This model contains copper coil, strong magnets and metal blade along with batteries.

This project is based on Lenz Law. Lenz's Law states that the direction of an induced electromotive force (EMF) is always such that it opposes the change in the magnetic flux that induces it. In other words, the induced current will flow in a direction that creates a magnetic field opposing the change in the original magnetic field.

This law was formulated by Heinrich Lenz in 1834 and is a fundamental principle in electromagnetism. It helps explain many phenomena, including electromagnetic induction, transformers, and generators.

### Application in a Manual Mixer Grinder

To apply this concept to a mixer grinder without electricity, we have designed a mechanism where the user manually provides the rotational energy to generate the necessary power to operate the grinding mechanism. Here's how it works:

#### 1. Manual Rotation of a Magnet or Coil System

Instead of an electric motor, the user manually rotates a crank or a wheel attached to a rotor with a magnet or coil system.

As the crank is turned, it causes a magnet to move in relation to a coil or vice versa. This motion induces a current in the coil (according to Faraday's Law of Induction), which generates a magnetic field.

#### 2. Induced Magnetic Field and Mechanical Movement

According to Lenz's Law, the induced magnetic field will act to oppose the motion that caused it. This means that the resistance you feel while rotating the crank is actually a manifestation of the energy being used to induce the current that drives the mixer's mechanical action.

The mechanical movement of this system (created by the user's effort) can be transferred through gears or belts to rotate the blades of the mixer grinder.

### 3. Resistive Forces and Energy Conservation

As the user applies force to rotate the crank, the induced current works against the motion. This resistance is necessary for the mixer grinder to function because the energy supplied by the user is being converted into mechanical work and electrical energy, which powers the grinding blades.

The system relies on converting manual energy into both electrical energy (to create a magnetic field) and mechanical energy (to drive the grinding mechanism), while Lenz's Law ensures energy conservation throughout the process.

#### Advantages of a Manual Mixer Grinder Based on Lenz's Law

**No Dependence on Electricity:** This model can operate in areas without electricity, making it suitable for remote locations or as an emergency backup.

**Eco-friendly:** Since it doesn't rely on an external power source, it reduces electricity consumption and is environmentally friendly.

**Exercise and Efficiency:** Manual operation provides an added benefit of exercise while still being effective in grinding, mixing, or chopping tasks.

#### Conclusion

A mixer grinder based on Lenz's Law works by converting manual mechanical energy into electrical and then back into mechanical energy, with electromagnetic principles governing the resistance and energy transfer. It operates without electricity, providing an innovative solution for grinding and mixing in an environmentally friendly and energy-efficient manner. The system is a great application of fundamental physics principles like Lenz's Law to create a useful, sustainable, and energy-independent kitchen appliance.

**23. School Name:** St. Joseph's Sr. Sec. School, Chandigarh

**Students:** Tijil Kanna, Saurabh Saroha and Abhijot Singh

**Project Supervisor:** Ms. Monica Chawla

**Project Name:** Krrishi Saarthi

Scan the code to  
watch the video  
of the project



## I. Purpose behind the development:

Traditional farming methods often require significant manual labour and time, especially for tasks like monitoring soil conditions, watering crops etc. To address these challenges, this project proposes the development of rover designed to help farmers in performing essential agricultural activities. The rover is equipped with advanced sensors and robotic features to monitor temperature and humidity, help in seed sowing, and perform precise irrigation. By automating these tasks, the rover reduces the need for manual labour, improves crop management, and promotes sustainable farming practices. The aim is to help the old and handicapped farmers.

## II. Scientific principle Involved:

The automatic seed sowing mechanism relies on principles of mechanics and automation. A motorized dispenser drops seeds.

Radio Frequency (RF) and Infrared (IR) technologies are used for remote control. RC uses RF communication, where a transmitter sends signals to the receiver on the rover to control its movement and actions.

Sensors like DHT11 are commonly used to measure environmental factors such as temperature and humidity. These sensors work by detecting changes in resistance, capacitance, or voltage due to environmental conditions.

The sprinkler system operates based on fluid dynamics and hydraulic principles. Water is pumped through pipes and released through a nozzle under pressure, dispersing over a large area. The solar panels are mounted on the rover's surface, allowing it to harness sunlight to recharge its battery throughout the day.

For measuring the soil moisture a soil moisture sensor is being used. In this, an electromagnetic pulse is sent through the probe inserted into the soil.

## III. Materials used for Construction:

- |                                  |                      |
|----------------------------------|----------------------|
| I. Arduino UNO                   | VI. Solar Panel      |
| II. Arduino Nano                 | VII. DHT11 Sensor    |
| III. Motor Driver Shield (L293D) | VIII. Li-ion Battery |
| IV. IR Receiver                  | IX. BO Motor         |
| V. Soil Moisture Sensor          | X. LCD Display       |

#### IV. Construction and Working of Exhibit:

It is a versatile and autonomous agricultural rover designed to streamline essential farming tasks. The rover can do automated seed sowing, real-time environmental monitoring, and efficient irrigation. By integrating remote control functionality with an IR sensor and receiver, the rover provides both manual and automated operation modes, enhancing flexibility and ease of use for farmers. The temperature and humidity sensors ensure that environmental data is constantly monitored, while the sprinkler system delivers water directly to crops as needed. It also consists of a Soil Moisture Sensor which measures the present moisture level of the soil. If the soil is dry the buzzer starts beeping, once the soil becomes moist the buzzer stops beeping. This combination of features reduces the farmer's workload and improves crop management. It also ensures sustainability as the batteries are charged using solar panel.

#### V. Applications:

1. Automated Seed Sowing.
2. Remote-Controlled Farming Operations.
3. Environmental Monitoring (Temperature, Humidity and Soil Moisture).
4. Efficient Water Usage through sprinkler based irrigation.
5. Solar-Powered Sustainable Farming.
6. Labour Reduction in Farming Tasks.

#### VI. Illustrations:

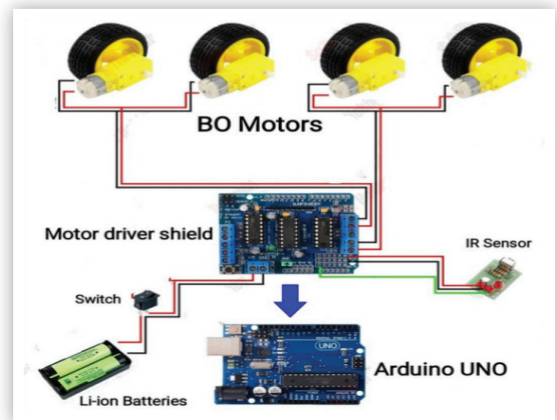
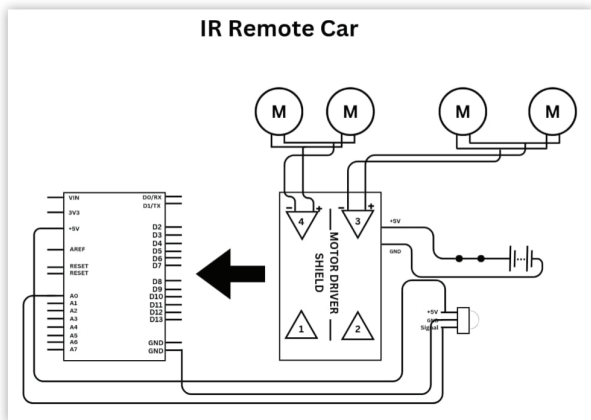

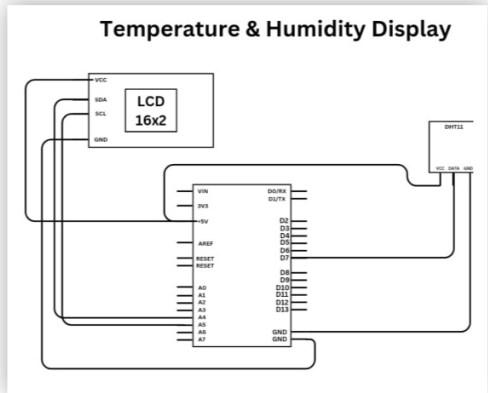
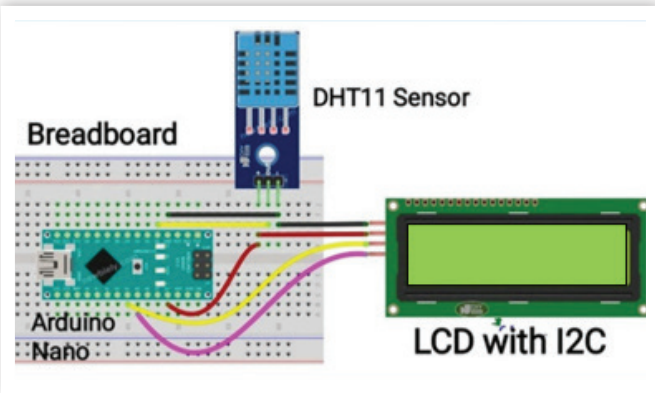
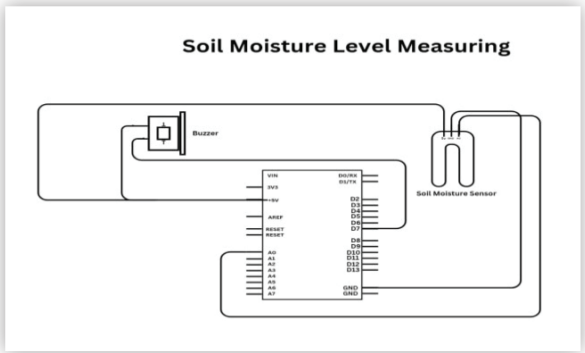
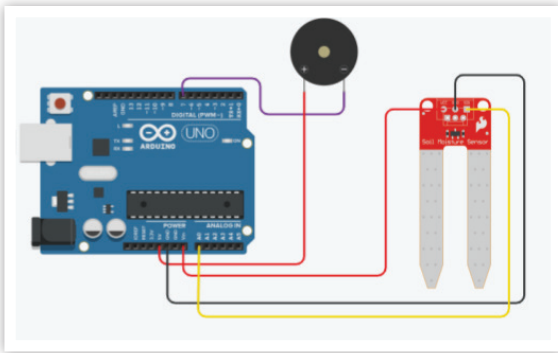

**24. School Name:** GD Goenka Signature School, Gurugram**Students:** Advita Pandey, Arhnav Kommu and Anik Singh**Project Supervisor:** Dr. Alpana Baveja**Project Name:** Gestro

Scan the code to  
watch the video  
of the project



The Bluetooth-Controlled Car project demonstrates the integration of hardware and software to create an innovative solution for wireless vehicle control. This project incorporates a microcontroller-based car equipped with a Bluetooth module and an Android application named Gestro, developed using the MIT App Inventor platform through blockbased coding.

### Overview

The car is powered by an Arduino microcontroller and uses an HC-05 Bluetooth module for wireless communication. It is equipped with DC motors controlled by an L298N motor driver, allowing precise navigation. The Gestro app acts as the control interface, enabling users can drive the car wirelessly with a smartphone.

### Gestro Application

Gestro is designed using the MIT App Inventor, a user-friendly platform that facilitates block-based coding for app development. The app features an intuitive and visually appealing interface that offers two primary control modes:

1. **Gesture Control:** Users can tilt their smartphone to control the car's direction (forward, backward, left, right).
2. **Button Control:** A set of virtual buttons allows manual control of the car for finetuned movements.

The app connects seamlessly to the car via Bluetooth, ensuring real-time response. The integration of gesture-based controls enhances the user experience, making it both engaging and interactive.

### Technical Specifications

- Microcontroller: Arduino Uno
- Bluetooth Module: HC-05
- Motor Driver: L298N
- Motors: DC motors for forward/reverse and left/right movement.
- Power Source: Rechargeable battery pack.

## Features and Benefits

1. **Wireless Operation:** Eliminates the need for physical connections.
2. **Gesture-Controlled Navigation:** Provides a modern, hands-free control experience.
3. **Real-Time Control:** Ensures smooth and precise movement without lag.
4. **Educational Value:** Introduces students to concepts of wireless communication, microcontrollers, and app development.

## Applications

This project can be used in educational demonstrations, robotics competitions, and as a foundation for advanced robotic applications. The combination of hardware and software exemplifies how modern technology can simplify tasks and inspire innovative solutions. With Gestro, users not only control a car but also explore the exciting possibilities of app controlled robotics.

**25. School Name:** The Manthan School, Greater Noida West

**Students:** Swasti Singh, Pragalb Singh and Virat Singh

**Project Supervisor:** Poonam Kumar Mendiratta

**Project Name:** Solar Powered Sand Batteries

Scan the code to  
watch the video  
of the project



## Introduction:

Solar powered sand batteries represent an innovative approach to renewable energy storage. These systems leverage solar energy to heat sand, which acts as a thermal energy storage medium. The concept addresses the intermittent nature of solar power by providing a method to store excess energy produced during peak sunlight hours for use when solar power generation is low.

## Mechanism:

**Energy Collection:** Solar panels or concentrated solar power (CSP) systems capture sunlight, converting it into thermal energy.

**Energy Storage:** The thermal energy is transferred to sand, which has high heat capacity and stability. Sand can be heated to temperatures exceeding 800°C.

**Energy Release:** When energy demand peaks or sunlight is unavailable, the stored thermal energy is extracted from the sand and converted back into electricity, often using thermoelectric generators or heat exchangers.

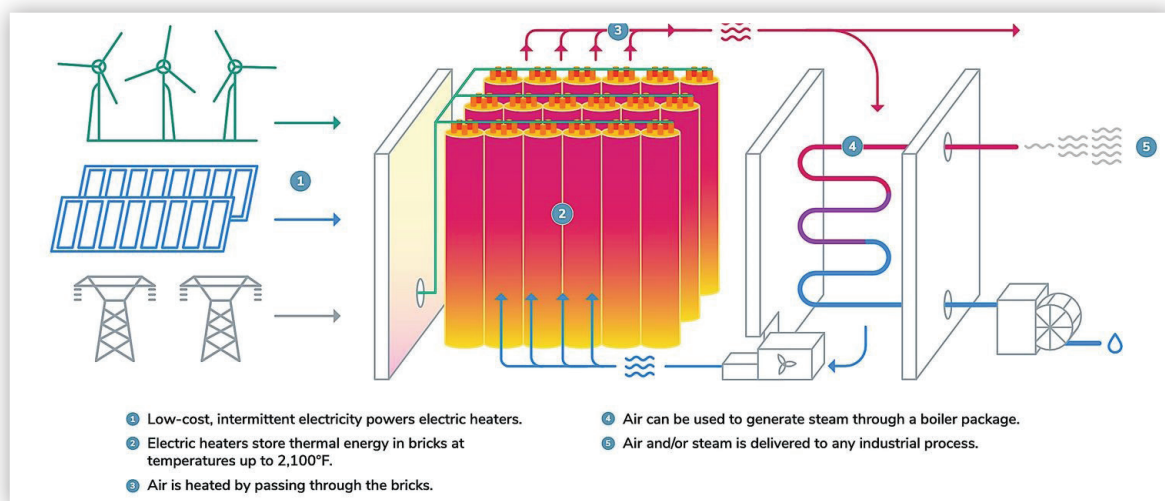

**Figure – 'Mechanism of Solar powered sand batteries'**

## Advantages:

**Efficiency:** Sand has excellent thermal conductivity and heat retention properties, making it an efficient medium for thermal storage.

**Cost-Effectiveness:** Sand is abundant and inexpensive, reducing the overall cost of the storage system.

**Longevity:** Sand does not degrade over time, providing a durable and long-lasting storage solution.

**Environmental Impact:** Utilizing solar energy and sand minimizes the environmental footprint, as it avoids the need for rare or hazardous materials.

## Challenges:

**Scalability:** Implementing sand batteries on a large scale requires significant infrastructure and investment.

**Heat Loss:** Ensuring minimal heat loss during storage and retrieval of thermal energy is crucial for maintaining efficiency.

**Conversion Efficiency:** Converting stored thermal energy back into electricity with high efficiency remains a technical challenge.

## Applications:

**Grid Stabilization:** Sand batteries can be used to stabilize power grids by providing a reliable energy source during peak demand times.

**Remote Areas:** They offer a feasible solution for energy storage in remote or off-grid locations where traditional batteries might not be viable.

**Industrial Use:** Industries with high thermal energy demands can benefit from sand battery systems to reduce reliance on fossil fuels.

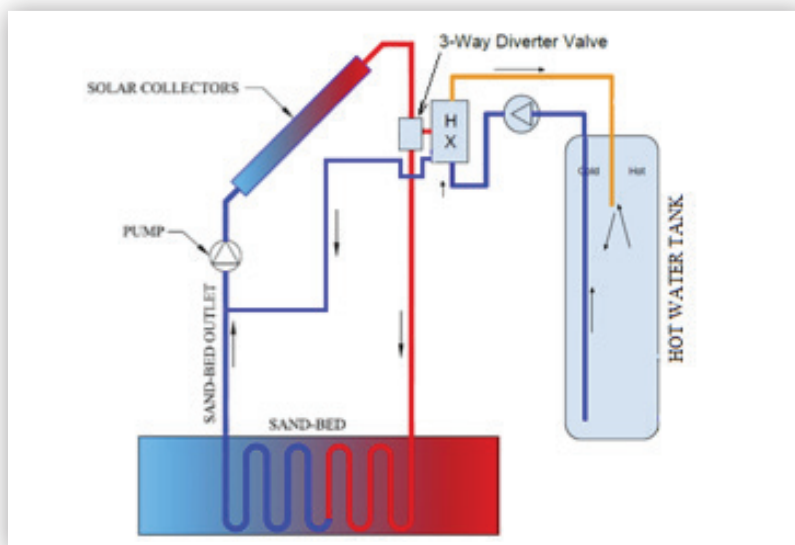

**Figure** – ‘Heating sand bed using hot water’.

**Future Prospects:**

Research and development in materials science and energy conversion technologies are expected to enhance the efficiency and feasibility of solar powered sand batteries. Innovations in thermal insulation and energy conversion processes will likely drive broader adoption and implementation of this technology, contributing to the global transition toward sustainable energy solutions.

**26. School Name:** K. L. International School, Meerut**Students:** Raghav Agarwal, Keshav Agarwal and Aryan Chaurasia**Project Supervisor:** Mr. Sudhanshu Shekhar**Project Name:** Arduino Self Driving Car with Automatic Street Light and Toll Plaza

Scan the code to  
watch the video  
of the project

**Problem Statement:**

A lot of energy and electricity consumption.

The increasing number of accidents day by day.

**Proposed Solution:**

Street light will be on when car pass by.

Using ultrasonic sensor so that car automatically stops when there is another car or any object.

Working of toll plaza without human intervention.

**Methodology**

**Results:**

Of car:

1. Ultrasonic sensor: stops the car when it senses the object.
2. Infrared sensor: keeps the car on track.

**Of Street Light And Toll Plaza:**

1. Infrared sensor: street lights on when car pass by.
2. Servo motor: pulls up and down the toll booth.
3. Future projects

We will add features to our car using different sensors like the bump sensors or the light sensors.

Purchase an Arduino-compatible color sensor and use it to detect traffic lights or traffic signs on our model roadway.

We will also add GPS for location and upcoming GPS toll system.

**27. School Name:** Spring Dales English School Changran, Kathua

**Students:** Sachi Sharma, Sadhya Sambyal and Jagruti Sharma

**Project Supervisor:** Ms. Neelam Gupta

**Project Name:** Aquafina- The Clearance of Water

Scan the code to  
watch the video  
of the project



“Aquafina” is a system that we created to clean the water from groundwater sewage, than the water could be used in. fields, homes, communities and many more.

## The Problem

We observed that agriculture is the backbone of our economy and groundwater is the main source of irrigation even after that the ground water sewage reduces the quality of the water used for irrigation, thus reducing the yield of the crop cultivated and also increases infertility of soil. We realized that we can solve this big issue by creating such a system that could be easily used by farmers.

## Hypothesis

We tried to find several ways to solve this problem and none of them were capable enough to solve this issue but only one of them was suitable and that was by using a whole system consisting of membranes, sensors, and other applications such as RO system. We find this suitable as this has an easy mechanism but it is effective too.

## Methodology

Primary Filtration consist of two-tank system with sponge membrane. Raw sewage is initially filtered through a two-tank system separated by a sponge membrane. This physical filtration process removes large solid particles and organic matter. Secondary Filtration system consist of RO membrane filtration. The partially treated water is then subjected to a more advanced filtration process using a prototype TFC (Thin Film Composite) membrane. This membrane removes dissolved salts, heavy metals, and other contaminants, producing high-quality water suitable for irrigation.

We have also used soil moisture sensing and irrigation control. A moisture sensor continuously monitors the soil moisture levels in the field. Based on the sensor data, the system determines the irrigation needs of the crops. The system triggers the water pump to deliver the required amount of treated water to the field through a drip irrigation system. Drip irrigation ensures efficient water delivery directly to the plant roots, minimizing water loss through evaporation and runoff. We can use the water in two ways and one of the ways is that this clean water can be use in the communities for various purposes like gardening, washing vehicles, utensils and clothes. It can be also used for drinking after boiling. For this, we have attached our model with a tank that is connected with the community’s water supply system and to ensure the ph of water we have attached a PH value sensor

to this tank. So that we can know the pH value of water that it is alkaline, basic, acidic or neutral. So this water can be used for various day to day activities and we can also ensure the pH value of water from pH value sensor and we can use the water according to its PH value. We have also used a TDS meter near the RO system. TDS meter is a small hand-held device used to indicate the Total Dissolved Solids in a solution, usually water.

## Conclusion

After testing different soil types and needs of different crops we can conclude these things:

- The system is nearly perfect for the growing problem of groundwater sewage, that gets used in irrigation, but to make sure the use of such system, can be only done by giving awareness about how this problem can solve this easily.
- This project can be a game changer in states like Punjab, Haryana, only for cleaning water also.
- This project ends the use of fertilizers to a great extent which in turn helps reduce soil pollution.

## Future perspectives

- We can use a better mechanism of RO system when being used in agricultural fields.
- The coding of the moisture sensor can be changed according to the need of the crop, for such crops as paddy as it requires more water.

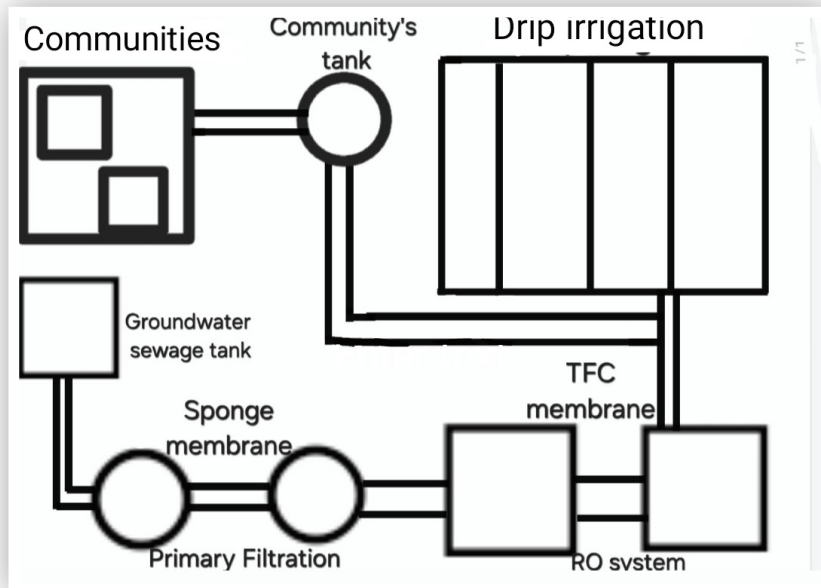

*Working mechanism of Aquafina.*

**28. School Name:** Kerala Public School Mango, Jamshedpur

**Students:** Rahat kalam, MD Arfat Salim Ansari and Mohammad Hasan Raza

**Project Supervisor:** Mr. Ankit Sharma

**Project Name:** Automatic fire extinguisher

Scan the code to watch the video of the project

**Introduction:**

An automatic fire extinguisher is a system that can automatically detect and put out a fire without human intervention. It is designed to react quickly to fire, reducing the damage and loss caused.

**Aim and objectives:**

The primary goal is to minimize property damage, equipment loss, and potential harm to human life to be able to operate without human intervention, ensuring protection even in areas where people might not be present at all times. The main purpose of an automatic fire extinguisher is to detect the early signs of a fire and alert the building occupants without human intervention. It reinforces the coverage provided by manual fire detection, providing protection for our premises even during periods of low occupancy.

**Principle:**

The principle of an automatic fire extinguisher is to use a heat sensitive liquid( eg: water) that expands. When the liquid reaches a certain temperature it causes the glass bulb to burst and release the extinguishing agent.

**Construction: Step 1:** First we connect 10 k resistor to the ammeter pin of BD140 transistor, 1k resistor to base pin of transistor. Now we fix the positive end of IR receiver LED with 10 k and 1k resistor and we take red LED and connect the negative end of red LED to collective wire of transistor. Then we connect 220 ohm resistor with positive end of red LED and negative end of IR receiver LED.

**Step 2:** In next step we connect the negative end of the pump to positive end of the pump with negative end of IR receiver LED. Then the battery and switch are connected and the negative end and positive end of battery is connected to the ammeter pin of transistor and negative pin of IR LED. we get the complete circuit and we fix the entire circuit in the plastic container.

## Benefits:

- Immediate response – Automatic fire extinguishers can respond in 10 seconds or less, stopping fires before they spread and cause damage.
- 24/7 protection – Automatic fire extinguisher can provide protection around the lock even when no one is present.
- Minimal human intervention – Automatic fire extinguishers are designed to put out fires without requiring human intervention.
- Safety in unmanned areas – Automatic fire extinguishers can protect areas that are unmanned or have limited human presence.
- Reduced property damage and lower insurance premiums.
- Cost effective – Automatic fire extinguisher can be prepared without Arduino device.

## Conclusion:

The automatic fire extinguisher project successfully demonstrates the potential of innovative technology to significantly improve fire safety by rapidly detecting and extinguishing fire without human intervention, providing a protective approach to minimizing property damage and safe guarding lives, the system's effectiveness in early fire detection, combined with its automated response mechanism, presents a valuable tool for residential, paving the way for enhanced fire safety measures across in various environments.

**29. School Name:** Sushila Birla Girls' School, Kolkata**Students:** Anushka Sinha, Vaibhavi Agarwal and Druhina Dey**Project Supervisor:** Chandrima Ghosh**Project Name:** Attendance Tracker

Scan the code to  
watch the video  
of the project



This innovative solution combines the power of computer vision and data handling to streamline attendance management in a reliable and automated manner.

The project leverages OpenCV, a popular computer vision library, to detect and recognize faces in real-time. Using a webcam or a similar video feed, the system identifies individuals and marks their attendance. This eliminates the need for traditional manual methods, which are often time-consuming and prone to errors.

**Here's how it works:**

**Face Detection and Recognition:** The system uses pre-trained models to detect faces and match them with pre-stored data. Each individual has a unique identifier, ensuring accurate recognition.

**Attendance Marking:** Once a face is recognized, the system logs the individual's name, date, and time into a CSV file. The CSV format is simple yet effective for storing and managing attendance records.

**Data Accessibility:** The CSV file allows for easy access and manipulation of data, making it suitable for generating reports or integrating with other systems.

One of the standout features of this project is its scalability. It can be deployed in various settings, such as schools, offices, or events, to manage large groups efficiently. Moreover, the use of OpenCV ensures that the system remains fast and responsive, while the CSV format keeps data handling lightweight and straightforward.

This system also addresses key challenges like ensuring accuracy, saving time, and reducing human intervention. For instance, by automating the process, we minimize the chances of errors caused by manual entry. Furthermore, integrating OpenCV with machine learning models can enhance the accuracy of face recognition, even in challenging conditions like varying lighting or angles.

In conclusion, our Attendance Tracker is a step toward smarter and more efficient attendance management. It demonstrates how modern technology, like computer vision and data processing, can revolutionize everyday tasks. We hope this project inspires further innovation and adoption of such tools in real-world scenarios.

**30. School Name:** St. Michael's School for Girls, Siliguri**Students:** Khushi Ali and Palak Agarwal**Project Supervisor:** Sewangi Singh**Project Name:** From Exhaust to **Innovation:** Turning Vehicle Emissions Into Sustainable Products

Scan the code to  
watch the video  
of the project

**Aim:**

This project seeks to mitigate urban air pollution by capturing harmful vehicle emissions and converting them into sustainable, innovative products. It aligns with the United Nations Sustainable Development Goals (SDGs): SDG 11 (Sustainable Cities and Communities), SDG 12 (Responsible Consumption and Production), and SDG 13 (Climate Action). By addressing air pollution and promoting a circular economy, the project aims to significantly enhance urban environments and quality of life.

**Concept and Implementation:**

Urban air pollution, primarily caused by vehicle emissions, poses severe environmental and health challenges. Exhaust gases contain particulate matter, nitrogen oxides, and carbon monoxide, all of which degrade air quality. This project proposes an innovative solution involving roadside installations equipped with carbon absorbers, HEPA filters, and carbon semi-filters. These systems capture emissions from passing vehicles without requiring any modifications to the vehicles.

Captured emissions, predominantly soot, are processed and repurposed into eco-friendly products:

- **Tiles:** Durable, practical, and aesthetically pleasing tiles offer a sustainable alternative to conventional materials.
- **Ink:** High-quality, eco-friendly ink made from soot serves as a replacement for petroleum-based inks.
- **Exfoliators:** Personal care products made from soot provide a sustainable alternative to chemical-based options.
- **Biochar:** A soil-enriching product that sequesters carbon and enhances agricultural productivity.

## Key Features:

- **IR Sensors:** These sensors detect vehicle movement and activate the emission capture system, signaling its operation with a green light. This ensures energy-efficient functionality by activating only when necessary.
- **Soot Monitoring Sensors:** These sensors track the filters' capacity and prevent over-accumulation.

## Advantages:

1. **Environmental Impact:** Reduces urban air pollution, enhancing air quality and public health by actively capturing harmful emissions.
2. **Sustainable Products:** Converts emissions into eco-friendly alternatives, reducing resource consumption and waste generation.
3. **Scalability:** The system can be deployed in cities globally, enabling widespread mitigation of air pollution.
4. **Energy Efficiency:** The reliance on solar power minimizes the carbon footprint and energy costs, making it an environmentally responsible solution.
5. **Cost-Effectiveness:** Low maintenance costs and solar energy integration ensure affordability for municipalities and governments.

## Sources and Inspiration:

- Data from the World Health Organization and pollution control boards highlights the urgent need to address urban air pollution.
- Research on carbon capture technologies provided the basis for repurposing emissions into valuable products.
- Advances in renewable energy and sustainable product development informed the system's scalability and practicality.

This project demonstrates how innovation and sustainability can converge to tackle urban air pollution while contributing to a greener future.

**31. School Name:** Vandya International School, Guwahati**Students:** Pragyan Rk Deka, Nishant Das and Ishan Afridi Parash**Project Supervisor:** Mr. Rajdeep Nandy**Project Name:** Smart home solution

Scan the code to  
watch the video  
of the project



As the name suggests, our project is based on smart home solution with a minimal human intervention.

The project integrates several innovative features, including an automatic gate opening system, an anti-theft alarm, a water tank alert, a fire detection system, and an automatic ringing bell—each utilizing specific technologies to address common household challenges.

The automatic gate opening system employs a pressure switch to facilitate effortless entry. As a vehicle approaches, the pressure switch detects its weight and automatically opens the gate, allowing for smooth passage. This system not only enhances convenience but also restricts access to authorized vehicles, bolstering security for the property.

In terms of security, the anti-theft alarm system utilizes laser technology to safeguard the home against intruders. A laser beam is set up across potential entry points, and any interruption of this beam activates a loud alarm. This precise monitoring of doors and windows ensures that any unauthorized access is immediately detected, significantly enhancing the overall security of the residence.

Additionally, the model features an automatic water tank alarm powered by a relay mechanism. This system continuously monitors the water level in the tank and triggers an alarm when the water reaches a predetermined level. By alerting homeowners to potential overflow, it conserves water and protects the property from the risk of water damage, reflecting the students' commitment to sustainability.

The fire detection system incorporates a zener diode, providing an essential layer of protection against fire hazards. The zener diode detects voltage changes caused by smoke or heat, triggering an alarm and alerting occupants to evacuate. This proactive approach enables timely action in the event of a fire, safeguarding lives and property.

Lastly, the home is equipped with an automatic ringing bell system that activates when someone steps on the stairs. Utilizing a pressure switch, this system detects weight and rings the bell, notifying residents of visitors. This thoughtful feature enhances convenience and ensures that no one goes unnoticed, contributing to a welcoming home environment.

**32. School Name:** The Brighter Academy, Imphal

**Students:** Narumbam Lanthenbi Chanu, Sarangthem Deepa Devi and Longjam Yaiphabi Devi

**Project Supervisor:** Mr. Soibam Sukumar Singh

**Project Name:** Solar Power Irrigation System

Scan the code to watch the video of the project



## Introduction

Solar Power Irrigation is a revolutionary approach to agricultural water management, harnessing the abundant energy of the Sun to power irrigation system. As the world struggle with the challenges of water scarcity, climate change and sustainable sources of energy and food production etc, introducing Solar Power Irrigation system as one of the solutions towards harnessing of sustainable energy will relief the vast challenges of farmers to some extent.

Solar Power Irrigation System can find applications in town water supply, livestock watering and irrigation. The Solar Power Irrigation System is an application of a solar-powered water pumping system used in paddy fields, and gardens for watering plants, vegetables, etc. This in turn, helps the farmers as well as the nation to some extent towards the exploration of eco-friendly and future sustainable form of irrigation.

## Description

Solar Power Irrigation System has four main parts:

**Solar panel:** Covert solar energy into electrical energy.

**Water pump:** Draws water from a source (like well or river). It has a motor running on electricity generated by the solar panel.

**Pump controller:** Manages the energy distribution from the solar panel.

**Irrigation system:** Distributes the water to the crops via pipes.



## Working

Solar energy is trapped and converted to electrical energy by using solar panels and this electrical energy is used to charge and stored inside a charger and battery system using electric wires.

This electrical energy is used to power the water pump to pump up water from water sources like rivers, lakes, wells, etc to the overhead water tanker through pipe lines.

At the same time, the water pump also transported and supplied this water from the overhead water tanker throughout the agricultural field through the irrigation system using network of pipelines.

The excess or used water is again allowed to follow to the water source through pipelines.

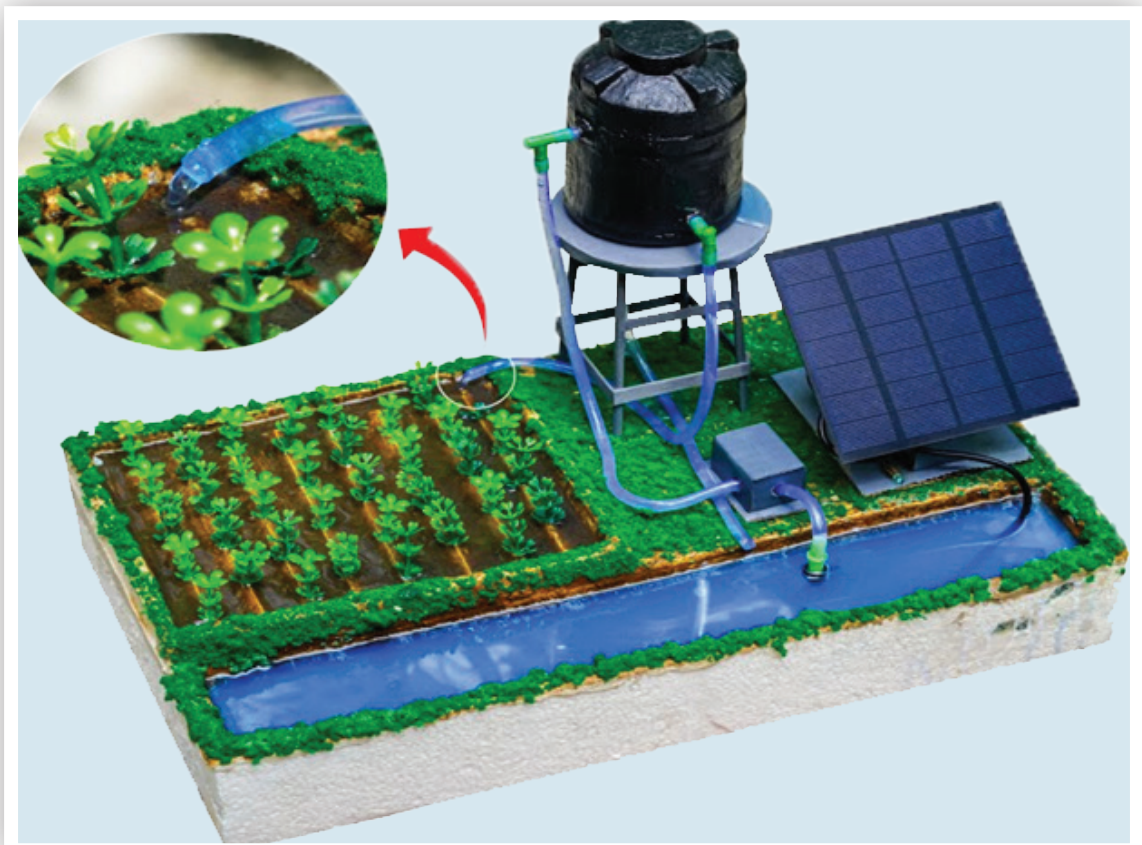

*A Mini Model of Solar Irrigation System.*

## Advantages of Solar Power Irrigation System

It makes irrigation possible in remote areas.

It is environment friendly.

No electricity bills to be paid.

It is durable, requiring minimal maintenance.

It is a positive approach towards the exploration of sustainable forms of energy.

Current Scenario of Solar Power Irrigation Systems in India.

Nearly 60% of Indians are farmers. But due to the lack of availability of electricity in remote areas, irrigation becomes very difficult and becomes one of the major issues in the livelihood of the people of rural areas even if the land is fertile and depends on rainfall only. Solar Power Irrigation System can save not only electricity but also save Indian farmers (during drought and scanty rainfall) who are otherwise prone to suicide.

Solar water pumping systems can make irrigation possible even in remote areas. The pumps are available for various types of irrigation, including paddy fields, horticulture farms, gardens, etc.

## Solar Power Irrigation System – Future Scope

With advancements in technology, the systems can be made more user-friendly. We can even control the motor pump from a remote location using mobile phone. We can get water level indication of the reservoir and overhead storage tank on our mobile phone. These technologies are already available in the market, though presently they are not so popular.

## Conclusion

Solar Power Irrigation System offers a cost effective and reliable system of irrigation for agricultural water management locally as well as globally. By harnessing (capturing and utilizing) the energy of the sun, it helps the farmers to approach an eco-friendly and sustainable source of energy, towards the development of agriculture.

**33. School Name:** Springdales dubai School, Dubai**Students:** Eashan Sharma, Pavjas Singh and Niteen Subrayan**Project Supervisor:** Aliya Amjad Waghu**Project Name:** Archa Vitae

Scan the code to  
watch the video  
of the project



We, Eashan Sharma, Pavjas Singh, and Niteen Subrayan, from Springdales School, Dubai, are proud to present our project, Archa Vitae, which addresses a critical environmental issue. Instead of depleting forests to meet the growing demand for agricultural land, we propose utilizing unused lands like Greenland to practice sustainable farming using our innovative solution, the Archa Vitae.

The Archa Vitae is an advanced machine engineered to overcome Greenland's harsh climatic challenges. It is equipped with cutting-edge technologies such as humidifiers, specialized lighting, heating, and ventilation systems, all of which work together to create an ideal environment for plant growth. This ensures that crops can thrive in areas previously considered unsuitable for agriculture. The system promotes sustainability by incorporating natural fertilizers and organic pesticides, making it an eco-friendly alternative to traditional farming methods.

Constructed with durability and efficiency in mind, the Archa Vitae has an aluminum outer layer for structural strength and a cork inner layer for effective insulation against Greenland's extreme weather. The machine's mobility is ensured by wheels for easy relocation, while anchors provide stability during operation. Additionally, the Hydro Hub, a key component of the Archa Vitae, purifies polluted water and supplies it to the LeafLink system.

The LeafLink system enhances crop growth by using natural elements like moss and lava rocks, which improve soil quality and optimize plant yield. Beyond cultivation, LeafLink manages pollination processes and doubles as a renewable energy hub. Powered by wind turbines and solar energy, it ensures energy self-sufficiency for the entire setup and functions as a reliable battery station.

For investors, the Archa Vitae offers an innovative and efficient farming solution. Priced at AED 1.7 million (\$462,833.16), it comes with advanced features, including remote management capabilities via CCTV and a dedicated sub-base for streamlined operation. Its compact dimensions of 10m x 10m make it both space-efficient and versatile, enabling deployment in diverse terrains while maximizing agricultural productivity.

The Archa Vitae is more than just a farming machine—it is a visionary leap toward sustainable agriculture. By transforming underutilized lands like Greenland into thriving agricultural hubs, it provides a practical, eco-friendly, and forward-thinking solution to one of the world's most pressing challenges.

**34. School Name:** Woodlem Park School Hamidiya, Ajman

**Students:** Ninan Negi, Renith Kizhakkeveetil and Rasil Ummer Kunnath

**Project Supervisor:** Ms. Saswati Biswas

**Project Name:** Garbage Robot

Scan the code to watch the video of the project



## Introduction

The Quarky Robot is an innovative garbage-cleaning robot designed to promote cleanliness and sustainability. It works in conjunction with a laptop for operational control, aligning with the Sustainable Development Goals (SDGs) by addressing environmental and societal challenges related to waste management.

## Objectives

- To automate garbage collection in public and private spaces.
- To utilize robotic technology for efficient waste management.
- To support the achievement of SDGs, particularly SDG 11 (Sustainable Cities and Communities) and SDG 12 (Responsible Consumption and Production).

## Sustainable Development Goals (SDGs) Addressed

- SDG 11: Sustainable Cities and Communities.  
Ensures cleanliness in urban and rural areas, reducing pollution and enhancing livability.
- SDG 12: Responsible Consumption and Production.  
Promotes efficient waste segregation and disposal practices.
- SDG 13: Climate Action.  
Reduces waste accumulation, contributing to lower greenhouse gas emissions from landfills.

## Components and Materials Used

- Quarky Board: Core microcontroller for robot functions.
- Sensors: Ultrasonic sensors for obstacle detection, infrared sensors for waste identification.
- Motors: DC motors for movement and garbage collection.
- Laptop: Acts as the control interface.
- Power Supply: Rechargeable battery pack.
- Chassis: Lightweight, durable frame for robot assembly.

## Working Mechanism

### System Architecture

- The Quarky board serves as the brain of the robot, interfacing with sensors and motors.

- The laptop is connected to the robot via Bluetooth, Wi-Fi, or USB for real-time monitoring and control.

## Operational Workflow

1. Initialization: The robot is powered on and connected to the laptop.
2. Navigation: Ultrasonic sensors detect obstacles, enabling smooth movement.
3. Garbage Detection: Infrared sensors identify waste materials.
4. Collection: The robotic arm or collector picks up the garbage and stores it in an onboard bin.
5. Disposal: Once the bin is full, the robot moves to a designated disposal area.

## Features and Advantages

- Autonomous Operation: Minimal human intervention required.
- Real-Time Data Analysis: The laptop processes data to optimize garbage collection routes.
- Environmentally Friendly: Promotes cleanliness and waste segregation.
- Scalability: Can be adapted for various environments, such as parks, offices, and industrial areas.

## Challenges and Solutions

- Challenge: Limited battery life.  
Solution: Use of energy-efficient motors and sensors.
- Challenge: Garbage detection accuracy.  
Solution: Advanced image processing algorithms integrated into the laptop software.

## Results and Impact

- Enhanced cleanliness in test areas.
- Increased awareness of proper waste disposal.
- Contribution to achieving SDGs by reducing waste-related environmental issues.

## Future Scope

- Integration of AI for smarter waste detection and segregation.
- Deployment in larger areas with multiple robots working in coordination.
- Solar-powered models for greater sustainability.

## Conclusion

The Quarky Garbage Cleaning Robot demonstrates the potential of robotic technology in solving environmental challenges. By aligning its objectives with the SDGs, the project not only showcases technological innovation but also contributes to building a cleaner and more sustainable future.

**35. School Name:** *Aspire Indian International School, Kuwait*

**Students:** Alvina Terrin, Anav Ramakrishnan and Antonio Jacob Jophy

**Project Supervisor:** Mrs. Rufee Shakeel Parkar

**Project Name:** Perpetual Motion Energy Generation Project

Scan the code to watch the video of the project



Perpetual motion refers to the theoretical concept of a machine or system that can operate indefinitely without external energy input. In reality, however, energy is always lost due to factors like friction and air resistance, which prevent true perpetual motion. Our model showcases this concept while also highlighting the challenges that scientists encounter in trying to achieve it.

In our project, we've used recycled materials, such as plastic bottles, wrappers, old bicycle wheels, waste wood, and iron rods, to create a system that converts mechanical energy into electrical energy. A motor is attached to the wheel, which is connected to a multimeter to measure the current generated. This is a sustainable approach to produce electricity—the faster the wheel spins, the more energy is generated.

However, our model eventually slows down. This is due to friction in the wheel's bearings, air resistance, and electrical resistance in the wires, which all lead to energy loss in the form of heat. While it may seem like the system is generating energy continuously, true perpetual motion isn't possible according to the laws of thermodynamics. Energy dissipation inevitably slows the wheel's rotation, meaning that additional energy would always be needed to keep the system in motion.

Despite these limitations, our experiment demonstrates how mechanical energy can be converted into electrical energy, offering a glimpse into the principles of energy transformation.

For future iterations, we plan to explore ways to keep the wheel spinning continuously by connecting it to a consistent energy source to produce a steady flow of electricity.





# HOW TO PARTICIPATE

Scan the QR Code  
for the nomination form



OR

## Eligibility

- **Classes:** 6 to 8
- **Team Size:** 3 students and 1 mentor teacher

**Last date to submit video: October 31, 2026**

**Last date to register: September 30, 2026**

Enter this URL in your browser: <https://macmillaneducation.in/macmillan-budding-scientists/>

## ARE YOUR STUDENTS...

### Looking in the right place?

- Searching online for ready-made project ideas
- Observing their surroundings and identifying problems worth solving

### Asking the right questions?

- Using theoretical answers
- Probing to understand the source of the problem

### Being original?

- Relying on available ideas online
- Developing possible options grounded in practicality

### Being thorough?

- Stopping at the first workable idea
- Following a problem-solving framework to build and refine a complete solution

### Thinking practically?

- Ignoring cost, feasibility, and impact
- Building solutions that are cost-conscious, practical, and mindful of the environment

## HOW TO NOMINATE

- 1 Each school must nominate a Coordinating Teacher who will be responsible for completing the registration and uploading all student videos. Coordinating Teacher automatically becomes the first mentor teacher.

- 2 For registration, an OTP (One Time Password) will be sent to the Coordinating Teacher's registered email ID. Once registration is confirmed, the teacher can add student details and upload the final video submission against each team's name. They can also add more mentor teachers.

- 3 Login access is available only to the registered Coordinating Teacher who can log in later using the registered mobile number, email ID, or Google login.

For queries write to  
**mbs@macmillaneducation.com**

# Macmillan Budding Scientists

Powered By SPRINGER NATURE

in association with Indian Institute(s) of Technology



YouTube



Scan the QR codes to watch year-wise  
videos of finalist projects



2024-25



2023-24



2022-23



2021-22



2019





For over 180 years Macmillan's pioneering spirit and reputation for quality has enabled us to build lasting relationships with teachers and educators around the world.

Macmillan Education is a global publisher with a local presence, where we connect with students, teachers, educational institutes and authorities. Since inception, we have advanced the learning curve for millions of students and educators with curated and innovative educational content and resources. Our solutions cater to everyone from children learning their first words to teachers looking to advance their knowledge and skills.



## 2025-26 WINNERS

The Emerald Heights International School  
Indore, Madhya Pradesh

 [www.macmillaneducation.in](http://www.macmillaneducation.in)

 [/macmillaneducationindia](https://www.facebook.com/macmillaneducationindia)

 [@MacmillanEd\\_Ind](https://twitter.com/MacmillanEd_Ind)

 [/Macmillan Education India](https://www.youtube.com/MacmillanEducationIndia)

Write to [mbs@macmillaneducation.com](mailto:mbs@macmillaneducation.com) for queries.